

GUIDE
FOR DRAWING
THE ACANTHUS.



rye, Del et Sc.

ACANTHUS - *Mollis*.

GUIDE
for drawing
THE ACANTHUS,

AND EVERY DESCRIPTION OF
ORNAMENTAL FOLIAGE;

By I. PAGE,
Ornamental Draftsman and Designer.

ILLUSTRATED WITH UPWARDS OF TWO HUNDRED WOOD-CUTS

AND

FIFTY-THREE ETCHINGS ON COPPER,

DESCRIPTIVE OF THE VARIOUS CHARACTERS ALLUDED TO.



London :

BERNARD QUARITCH.

re-printed 1886.

MR



OPINIONS OF THE PRESS.



“ We feel an apology due to Mr. Page, for not before noticing his truly and interesting and highly useful Work, which, (at this period, when the florid ornamental style is so predominant, not only in engravings, but in cabinet work, and in the fittings-up of shops, and interior of houses) must be a valuable instructor, to all inlayers, modellers, cabinet-makers, ornamental workers, and carvers, and also to students in every department of the fine arts—to engravers on wood for designs and instructions for ornamenting capitals, and head and tail-pieces—letter-founders, for new and chaste patterns for flowers;—and, as the splendidly-ornamental shop-bills which shed such a brilliant lustre on the artistical talent of the last century, are now being happily revived, ‘Page’s Guide’ will be to them of the most vital importance.

“ The letter-press remarks and instructions in the first part are illustrated by innumerable beautifully engraved specimens of the various schools treated of, designed and engraved by the talented author; reflecting on him the highest credit as a writer and artist of pure taste and varied talent.

“ This production has our heartiest commendation; fearlessly and earnestly recommending it to all lovers of the fine arts. Young ladies with the assistance of the above work, may, with the greatest ease, exercise their judgment by forming fanciful borders for the pages of their scrap-books.

“ It is really gratifying to witness such a concentration of genius emanating from one of the British school, and in that peculiar branch of art wherein we have hitherto looked only to foreign countries for examples ; it proves, also, the truth of our oft-repeated assertion—that, if patronized, our artists can rival those of any country. We again especially implore our young and fair readers to cherish and uphold, to the very uttermost of their power, let it be however insignificant, the talent of our beloved country, and not to be led astray by the present *fashionable* predilection for those innumerable muddy-looking and ugly productions of foreign artists, which unfortunately disgrace the shop-windows of our book and print-sellers, and are purchased and prized merely because they are the works of strangers, whilst our own artists are literally starving for want of employment.”—*Mirror*.

“ The producer of this Work—for he is, it appears, the author, editor, designer and engraver of it—is one of the masters at the School of Design ; and his object in publishing is to afford easy instruction by certain rules to enable the young draftsman to base his designs on safe and secure foundations. It is a most creditable production ; one that will interest all classes, and be of rare value to those whom it more especially concerns. The Author exhibits proofs of great industry as well as of patient research ; and where his own inventive powers are applied he is eminently successful. The book abounds in explanatory illustrations of all the subjects considered : the style is clear and comprehensive ; the merest tyro in art may study it with advantage. We rejoice to welcome a publication of the kind ;—our English ornamental designers

are nearly all of them slavish copyists, and scarcely dream of thinking for themselves, while they can beg, borrow, or steal from the wits of France. The School of Design has already done something to lessen this crying evil, and will, no doubt, ere long achieve much more; meanwhile this cheap work, issued, with upwards of a hundred engravings, and one hundred and fifty pages of letter-press, will, we trust, attract general attention, and recompense the producer of it, by forwarding the purpose for which he labours. We shall refer to it again."—*Art Union, April 15.*

"This Work is one of the best and cheapest that has been written on the subject, and from the pen and pencil of a practical man, who has had the advantage of being able to see his instructions carried into effect under his own inspection, as director of the class of ornamental drawing at the School of Design; as a further recommendation of the Work, it is worthy of mentioning, that the illustrations proceed from the graver, as well as the pencil of Mr. PAGE."—*Civil Engineer and Architects' Journal.*

"We hail with pleasure this Work, it has been long wanting in the Schools of Art: the rules are explicit, and the matter interesting and instructive; we wish he had treated further on the vine leaf, that being much used by the ancients; we doubt not but its success will repay the labours of the Author, who is the Alpha and Omega of the Work."—*Polytechnic Journal.*

"We have before us an entire and new Work, entitled 'PAGE'S GUIDE TO ORNAMENTAL DRAWING AND DESIGN,' the plans and

contents are such as must inevitably repair that loss usually found in our Schools of Art ; we wish the spirited and talented Author every success ; the letter-press is excellent, and the plates well got up.”—*Literary World*.

“This is a Work in which great spirit for the benefit of the Arts is shown ; the rules laid down are excellent ; the whole of the Work is completed by the Author, which, to praise too much would appear a boast ; it is illustrated with innumerable wood-cuts and plates. We wish the Work every success, and, in our opinion, no school or student should be without it.”—*Weekly Dispatch*.



GLOSSARY OF TERMS

USEFUL TO DRAFTSMEN.

- Abacus*, the upper member of the capital of a column.
- Acroter*, a pedestal on the summit of a column for supporting a statue.
- Acroteria*, small pedestals placed on the apex and other extremities of a pediment, originally intended to support statues.
- Antæ*, pilasters attached to a wall.
- Ashlar work*, rough stone laid in irregular courses.
- Bevelled*, sloped off.
- Buttress*, the projecting portion of a building, used generally to strengthen a wall as well as give effect, in Gothic architecture, and when separated from the building by an arched piece, it is termed a flying buttress.
- Campana, or Bell*, that part of the Corinthian cap, on which the foliage is placed, and on which the abacus rests.
- Cap of a Chimney*, the upper and projecting part of the shaft.
- Capotum*, a kind of Hindû torus moulding, with an ornament resembling a pigeon's head at its termination.
- Cella*, the part enclosed by walls of a Grecian temple.
- Check-plate*, the piece of wood in the lintel of a doorway, against which the door shuts.
- Chevron moulding*, an indented moulding in the Anglo Norman style.
- Chimney shafts*, the part of a chimney which rises above the roof.
- Cincture*, a ring or fillet serving to divide the shaft of a column from its capital and base.
- Clere-story*, the centre of a church, when it rises above the two aisles.
- Clere-story windows*, windows in ditto.
- Coins*, corners.
- Congee*, a species of moulding.
- Corbel heads*, the extremities of corbel stones,—often carved.
- Corbelled*, one stone projecting over another to support a superincumbent stone.
- Corona*, the crowning member of the entablature.
- Corrugated*, wavy or fluted.
- Crowsteps*, the coping stones of a gable rising one above another.
- Crypt*, a vault.
- Cumuda*, a kind of Hindû circular moulding.
- Curbed*, contracted towards the ceiling by being carried up into the roof.
- Cusps*, points formed in the upper corners of the window by uniting the two curves.
- Cyclopien walls*, walls built with land stones heaped on each other without mortar and irregular.
- Dado*, the flat side of a pedestal between the plinth and the cornice; applied also to the space between the skirting and the chairs' back moulding in rooms.
- Dormer windows*, windows in a roof.
- Dressings to windows*, mouldings, or rather architectural lines and forms surrounding windows, so as to prevent them from being "mere holes in a wall."
- Echinus*, a species of moulding.
- Engaged columns*, columns attached to a wall, and projecting from it half or three-quarters of their diameters.
- Entablature*, a horizontal mass placed on Grecian columns: it consists of three parts—the architrave, frieze, and cornice.
- Epistylum*, or architrave.
- Facade*, the principal face, front, or elevation of any building.

- Fascia**, the face or principal member of the architrave, generally divided into three parts, to the Ionic, Composite and Corinthian.
- Festal**, a pointed ornament terminating a gable, in Gothic architecture.
- Frets and guillochis**. Frets are ornaments composed of a series of small straight fillets; and guillochis of a series of curved fillets, intermixed with straight lines.
- Frieze**, the plain surface between the corona and cornice, on which the triglyphs are placed in the Doric, and ornaments in the three remaining orders.
- Frustum of a pyramid**, the lower part, the upper having been cut off horizontally.
- Greek cross**, a rectangular cross, the limbs of which are all equal.
- Haunches of an arch**, the part behind the springing of the arch.
- Intercolumniation**, the distance between the columns of any building.
- Label moulding**, an outer moulding, crowning a door or window head, always returned at the ends.
- Lancet windows**, windows formed with lancet heads, in the pointed style.
- Lintels**, the side pieces of a window-frame or doorway.
- Lotus ornaments**, the water-lily used by the Egyptians.
- Minutes**, division of 60, for working the orders of architecture, the foundation being the width of the base of any column.
- Modules**, equal parts into which a diameter is divided, for the purpose of facilitating its measurement or delineation, and then into minutes.
- Mullions**, upright pieces, dividing a window into three or more parts.
- Mutules**, the modillions in the Doric order are called mutules.
- Neck of a chimney**, the part immediately under the cap.
- Novel**, the turning-post of a staircase.
- Octostyle**, a building with eight columns in front.
- Pagoda caps**, caps for ventilation.
- Palm-leaf ornaments**, leaves of the palm, in general used by the Romans.
- Patera**, an earthen cup, or vessel, used by the Romans.
- Patera**, an ornament something like a rose, used to conceal small openings.
- Pilaster**, a rectangular pillar attached to a wall.
- Pinnacle**, a pointed ornament terminating a pediment, or buttress.
- Rustic-work**, stones made rough, on the outer surface, by tools. There are several kinds of rustic-work; the most common of which are the lined, in which the hollow marks are in straight; and the vermiculated, or wormed, in which they are in curved or tortuous lines.
- Soffite**, the ceiling or under side of any member, or mouldings in a cornice.
- Spandrels**, the space between the springing of an arch and the flat surface it is intended to support.
- Splayed**, bevelled off.
- String-courses**, marked and projecting lines of separation on the face of a building.
- Tazza**, a cup.
- Triglyphs**, certain distinctive marks in the frieze of the Doric order, and formed by three glyphs, or grooves.
- Vestibule**, an ante-hall, or inner porch.
- Volutes**, scrolls of the Ionic, Composite, and Corinthian caps.

CONTENTS.



	PAGE.
HISTORY AND RULES FOR DRAWING THE ACANTHUS MOLLIS, PERPENDICULARLY	1
RULES AND PRACTICE FOR DRAWING CURVILINEAR FOLIAGE, AS ADAPTED TO RUNNING SCROLLS AND CORINTHIAN CHAPTERS	21
ON STARTING POINTS	80
ON GRECIAN AND ROMAN ORNAMENT	89
ON THE DESIGNING OF TROPHIES	112
ON SWORDS AND OTHER ARMS	117
ON EGYPTIAN TEMPLES, HIEROGLYPHICS, SACRED ANIMALS AND COLUMNS, SUITABLE FOR EGYPTIAN DECORATIONS	120
ON FRENCH ORNAMENT, WITH A VARIETY OF RULES FOR COMPOSING THE SAME	134
ON FRETS AND GUILLOCHIS	156
ON ARABESQUE	160
ON ELIZABETHAN	167
ON GOTHIC DETAILS, AS REGARDS CURVILINEAR PORTIONS AND PERIODS	210
ON GEOMETRY	221
ON MOULDINGS	239



PREFACE.

IT has often appeared to the Author of the "GUIDE TO ORNAMENTAL DRAWING," that, notwithstanding the many valuable works that have been, and are at present publishing on ornament, from various foreign works, and ancient edifices, that some other was required to prepare the pupil and student, not as copyists, but for a much higher class in the art, viz., their own designers; to accomplish this has not been a very easy task. After many years' study, as a self-taught draftsman, difficulties continually arose on the principle I followed, as a basis for improvement,—that of never copying, but holding retentive in my memory all I saw, until I transmitted it to paper, and then referred to my origin, and corrected accordingly; and thus I proceeded, keeping in mind a boldness and freedom of hand, which, when acquired, always holds a predominancy in the arts, over the frippery, patched, and meagre line, which is aimed at by many; and, like all injurious habits, easily acquired, but not so easily amended. After studying until I accomplished my object, that of dissecting and obtaining a thorough knowledge of all the various ramifications

belonging to the many characters or styles in general use, and seeing the difficulties that appeared to others in copying from different works, for the want of perseverance to take the right method. Pupils are generally taught (*merely to please their parents and spoil paper*) to commence drawing a forest, without first knowing how to draw the bough of a tree, and on this plan many who receive instruction at schools are spoiled, whose innate ideas, if properly trained, might have filled the vacuum now existing in our British schools of art and manufactures. The object of this work occurred to me about five years ago, and after trying many geometrical diagrams, those contained in this work occurred as being the most simple and efficacious, but yet had not sufficient confidence to bring them forth to the public, without first knowing their value. Subsequently I commenced throwing them open to all who thought proper to follow them, which has been by no means few; and the principles laid down in this work have since been duly appreciated, both by connoisseurs and amateurs, and in no instance have they failed. By the request of many friends, I revised them well, with a determination to throw them open to the public at large, with feelings of arduous enthusiasm, which was really wanted to aid and improve the art of design. Being dubious in entrusting the spirit of my wishes to another, I commenced this work as Author, Engraver, and Printer, resting assured, under this impression, that, where I may have shewn a

want of classical literary attainments, it will be pardoned on the part of my numerous subscribers,—my only wish being to give that instruction under confined heads of explanation; the engravings not as first specimens of art, but give that outline and form which is usually lost sight of when so much labour is bestowed. It is hoped, therefore, that this work will afford that assistance as a self-instructor, and be a valuable auxiliary and remembrancer to the universal draftsman,—it will then repay the labours of yours, obediently,

I. PAGE.



RULES FOR DRAWING

THE

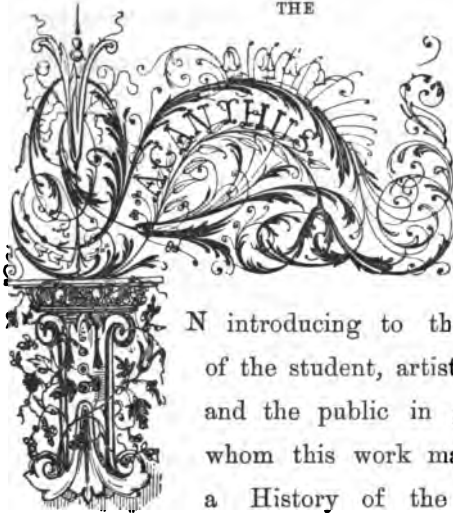

N introducing to the attention of the student, artist, mechanic, and the public in general, to whom this work may concern, a History of the Acanthus, solely of its being first brought into notice, as regards the adaptation in architectural details, would be of little service, although known to many, and yet to the youth and others unacquainted with it, it may be interesting, if not original. A virgin died at Corinth, and being buried under or near a pyramidal tomb, her nurse or companion, after her interment, placed her jewels, &c., for which she shewed a partiality when living, in a wicker casket by the tomb; and, for safety, placed a tile on the top to avoid

the atmosphere, for the longer preservation of its contents. This tribute being placed on a root of the *Acanthus*, (*acanthus mollis*,) commonly called bear's breach or brank ursine, (in botany a genus of plant belonging to the *dydynamia angiospermia* class, or the *spinosa acanthus*, commonly termed the dock leaf,) is uncertain ; but in the spring it burst forth and spread itself fantastically around the casque. Nature having given the design, one day, a celebrated architect and sculptor, *Calamacus*, who, for the delicacy of work upon marble, and genteelness of his invention, was by the Athenians surnamed *Catatechnos*—that is to say, Industrious—passing near this monument, cast his eye upon the image before him, and began to consider the pretty tenderness and playfulness of the foliage which grew about it; the manner and form whereof so much pleased him for its novelty, he copied it in its rude state, and with his powerful imagination added and improved it to a graceful modelled form: shortly after, erecting columns at Corinth, he capped them with this

new idea and ordained its symmetries, distributing afterwards in his works proportions equal and agreeable to each of its other members in conformity to his the Corinthian mode.

Vallalpandus must needs give to it a more illustrious and ancient origin. He pretends to assert, that the Corinthians copied it first from the temple of Solomon, of which God himself was the architect; and, better to elude the previous account, states that the Acanthus was rarely used by the ancients; and by the description of this divine piece of architecture, there is no doubt that the originals of the temples were of palm branches bearing fruit, to which the leaves of the olive have a near correspondence. The finest example of the ancients in the adaptation of this description of foliage, was the frontispiece to the Torre de Nerone, in Rome, which has been destroyed within the last century and a half, to the great reproach of the age, by the avarice of some particular persons: this was one of the rarest specimens of antiquity, not only for the richness of its orna-

ments, but for the contour of its different members; the columns were six feet in diameter. It is not precisely known by whom it was caused to be erected, or to what purpose; some imagine it was a temple erected by the Emperor *Aurelianus*, and dedicated to the sun; others, that it was only a palace. Another tradition asserts that *Nero* raised it to behold the conflagration of Rome, which is very improbable, being too great a work to have been accomplished in so short a time. Be it what it may, certain it is, according to the splendid illustrations of its different parts, it was the most magnificent specimen of Corinthian architecture that Rome could boast of. Other specimens of this order are in the chapters of the baths of Diocletian, in which the volutes are of ram's horns; this temple was built by *Pyrrho Legorio*, in the year 1574. In the temple of Jerusalem, the chapters of the columns were entirely of the palm leaf. The castle of Lions, at Verone, and the arch of Titus, were of the composite order, and erected to the glory of that emperor, on his return from that famous

enterprise, the siege of Jerusalem. The frieze of this arch portrayed the spoils and ravages of the temple; moreover, this arch was the first of its kind of structure; mentioning these specimens are not to deteriorate from the specimens of the present day, far from it; but, as these were the originals, and from whence our present architects derived their knowledge, not only for the different orders, but for their symmetries, which they, as men of sound sense and reason, will allow, that if these rules are deviated from, all is thrown out of proportion, and never attracts the eye of the common observer with that grandeur which even a common print of an ancient edifice would do.

I shall continue my description a little farther previous to delineation, as it may be acceptable to many. According to *Virgil*, the Acanthus is an evergreen plant, producing berries, or a small round fruit. *Theophrastus* describes it as a prickly tree and bearing pods, like beans, of which, in some instances, we have no reason to doubt; for on examining works



of Roman and ancient architecture, upon the friezes will be seen starting stalks and pods between the scrolls, as is heretofore represented. The Greeks used the cultivated Acanthus, (*Spinosa*,) it being smaller in its parts, and more suited to the style and taste of that country. In respect to this description of ornament, the author has made it his study to simplify it by rule, that any person, commencing to draw ornaments for sculpture, stonemasonry, modelling, plastering, and carving, on whom rest the execution of that portion of the work from the architects and designers, who for the want of such foundation to work upon, render such undertakings extremely difficult, is the reason that the following rules have been studied to facilitate and bring a correct principle into design. It would be wrong to assert that lessons have not been laid down before, yet in so complicated a style, that not only places it beyond the easy comprehension of the workmen, but is generally beyond their circumstances to obtain such valuable works: the present is far more simple than

any yet brought forward to the public, and with trifling study and perseverance would render the draftsman and mechanic perfect in this and every other description of foliage.

It is surprising that no other foliage than the Acanthus is ever made mention of by any ancient or modern writers. *Ovid* mentions it in representing an immense vase of bronze, adorned with a mythological story, the border being covered with the flexible Acanthus, wrought in gold. *Pliny*, the younger, asserts it is nature's chosen plant, for, throw it in whatever form you may, certain it is to fall into graceful curves. *Athenaius* relates that the canopy ordained to convey *Alexander the Great* to Egypt, the car was of golden columns, intermixed with the rich foliated Acanthus. The observation of the celebrated French author, *De Cordemoy*, is very rare, but very true : it is strange, he observes, people soon cease to esteem that which is natural; nature and reason must always be violated, and we prefer a confused jumble of painted leaves of the laurel or olive, to the simple and graceful

contours of the Acanthus: how well this speaks of the many trials that have been made in designing to alter this foliage, still a substitute has never yet been found where such freedom and beauty exists; some attempts are very good, but they are sure to fall into the original appearance, and when once a fundamental rule is got perfect, how soon will the student be able, with strict attention, to arrive at that state of perfection which must repay all his labours, with the pleasure of conquering, and making every study in design easy in itself.

I think sufficient has been said respecting this description of foliage, and as every other has been derived from that one, except sundry variations and styles, of which each will be explained in its due course and place. We will now commence delineation of the first four rules, to complete an Acanthus leaf to any dimensions. Rule 1, plate 1, is the first outline or base principle of the foliage.

Draw a perpendicular line, *a b*, to whatever height you may require, or think proper, being

careful to have the width of your base, or horizontal line in due proportion, which is half the height, or thereabouts, according to the situation in which it is to be placed; but I have found half to be sufficient, and on those principles the chief of my illustrations will be formed. Your base line, *c c*, is to be divided into six equal parts, one of each, *d d*, from the perpendicular line, will give you where to start your conical lines to form the pistules on; then divide the perpendicular line into five equal parts and one-fifth, will give you the springing for the head, or circular portion of the leaf, which starts from a line drawn parallel with your pistule line, as this small diagram will shew:

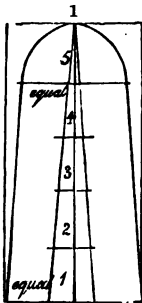
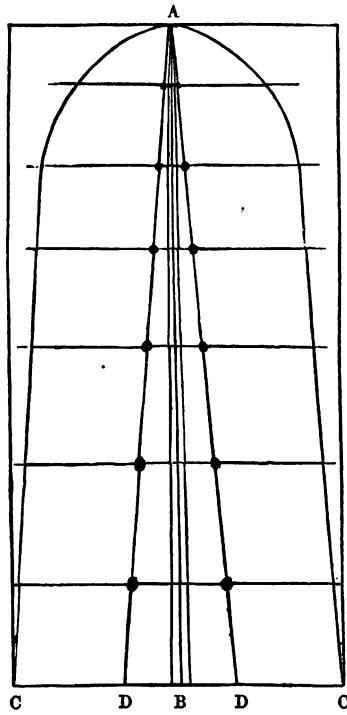
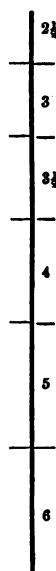

Plate 1 will shew you what sub-division to proceed with previous to forming the exterior line of the leaf; and better to prove it, we will suppose that I have a given size to execute an Acanthus foliage, height 2 feet, base

PLATE 1.



1 foot. I will make this my outline, according to the previous diagram; now, I have 24 inches to compose six ruffled leaves on each side of my perpendicular line, the bottom or base of the leaf is always the largest, consequently we may give most to that, and gradually diminish as we rise to the top, so that the bottom ruffle



2 $\frac{1}{2}$ will be 6 inches, then 5 inches, 4 inches, 3 $\frac{1}{2}$ inches, 3 inches, and 2 $\frac{1}{2}$ inches for the top, which, properly curved, will give the same appearance as plate 1; having done this, the plan is laid for plate 2, which shews the exterior plan; on each intersecting line you can form a dot, and from this dot you will carry your pistule and starting of the leaf; then by gradual curves, rising from these points, and meeting the next one as if it were passed through the leaf, as the following diagram shews.

You perceive that you have a leaf in fact, which, on gaining this point perfect, I may say the greatest part is conquered, as on this rest all

the grace of the foliage afterwards. I will now leave the diagram lines and proceed with plate 3, where the contour of plate 2 is kept by the dotted lines, and by dividing each of these leaves into three parts, as will be seen by diagram 3,

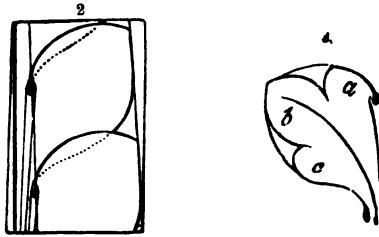

you have the third process complete, and gives you where to terminate the centre stalk, or stamina of the leaf, which runs between each pistule, as the enlarged accompanying diagram will shew; on this alone depends the freedom of the foliage, and this rule applies to every department of scroll work whatever, or however curvilinear it may chance to be,—this is very feasible upon consideration, as this foliage is a portion of a plant, of course every fibre must arise from the base or root, and to whatever

PLATE 2.

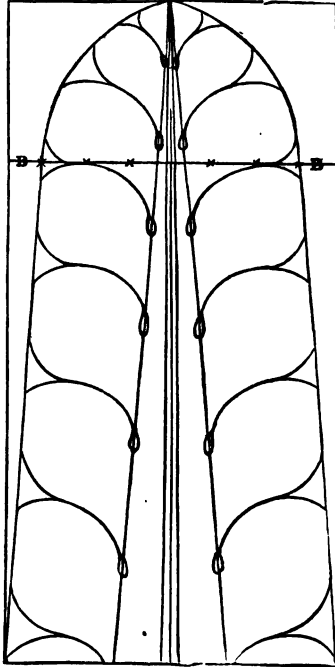

In this figure you will perceive the perpendicular line is divided into only four parts, and B B the springing points.

height or size, the origin is the same, or whatever way it may have grown. I do not say it is necessary to illustrate this, but to prevent mistakes, another shall be placed aside the scroll, to prove that should any other course be taken than heretofore mentioned, a peculiar character would appear, and out of all proportion, yet correct. You will see by these two diagrams the principle of my ideas.

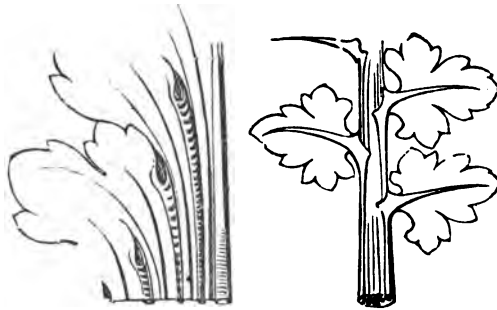

* P S P S P S P S Stem.

Return to plate 3, the dotted lines will shew the principle of my previous explanation. Plate 4 will soon convince the reader of the true working of my diagrams: here is a leaf, on one side,

* P Pistule.—S Stamina.

G. & C. CO.

Fig 6

Fig 5

Fig 4

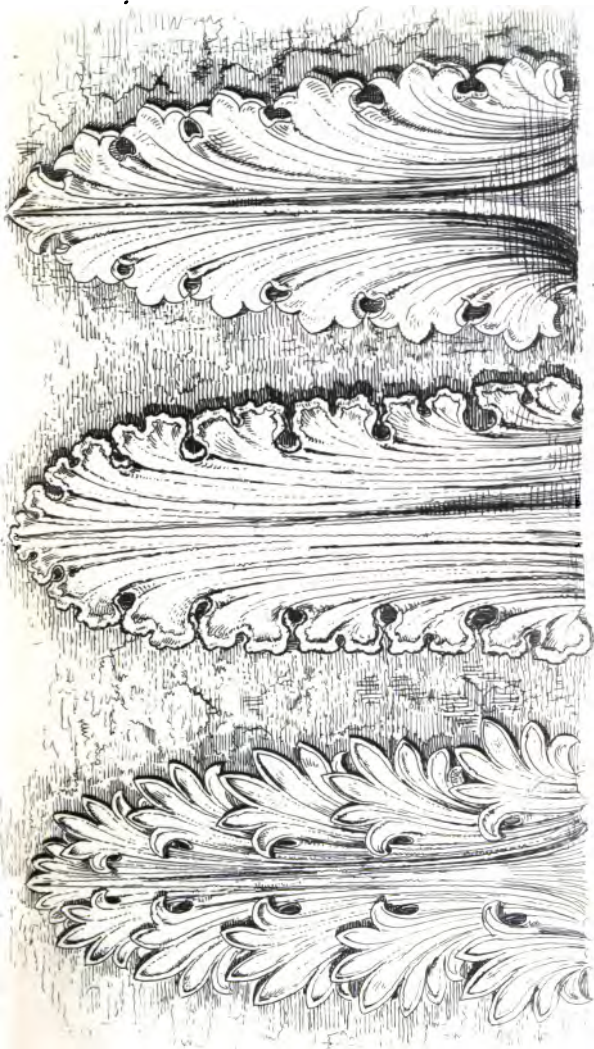

Trefoil

Deck

Panel

Base Mould

stript of all adjacent lines, and on the other is another sub-division of three parts, which complete the leaf to a certain extent, according for what it may be required; as on this point the effect of many splendid designs are lost; they are worked to the greatest nicety, and when elevated, they form a confused jumble, and the architect, and others connected with it, are blamed;—for friezes, plate 4, is sufficiently cut at the edges. You are not to suppose that when you have arrived as far as plate 4, that you have the leaf finished in so chaste and rich a style as it is sometimes required, far from it, the edges ruffling of that leaf is termed *dentata*, or tooth-shaped; this is sufficient when properly drawn, as plate 5, for friezes, modillions, mouldings, &c., or where altitude is required, as the height reduces the parts to the eye, and it looks perfect and rich to the passing observer; be it as it may, this rule must be got perfect before you commence with plate 6. Here is a leaf as perfect and chaste as ever need be used on any department of work, either for foliated capitals, orna-

PLATE 3.

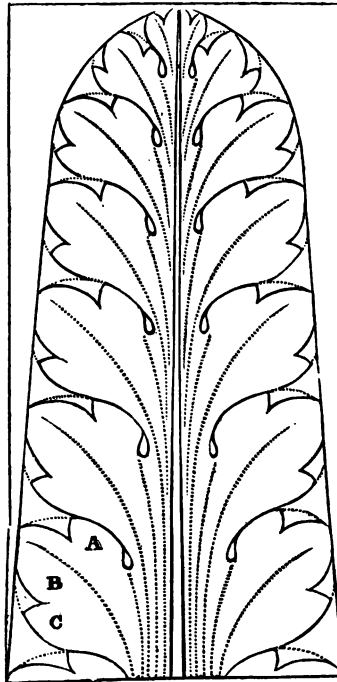

mental embroidery, carving, or modellings, but chiefly for vases, bosses, ceiling ornaments, or wherever this style is required near to the eye. The same rule may be gone through to draw this foliage, as plate 1, 2, 3, and 4; and the whole of the leaf may be completed in the same style and character as plate 6; and for a running scroll, or frieze, on a small scale, no leaf can look more rich and perfect, as will be shewn in the following numbers; in which every department of curvilinear foliage will be treated on and illustrated; thereby gradually producing portions of foliage, springings, headings, and terminations of bosses, &c., generally used in friezes and other description of scroll-work, that every separate piece when put together shall form a series of designs, and prove how easy a student may become his or her own designer.

PLATE 4.

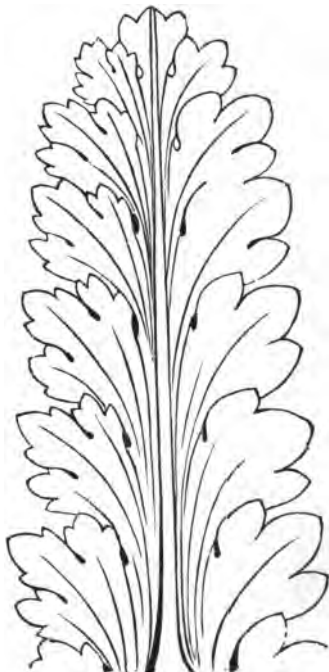

PLATE 5.



REESE ^{2*} LIBRARY
OF THE
UNIVERSITY
OF CALIFORNIA

PLATE 6.

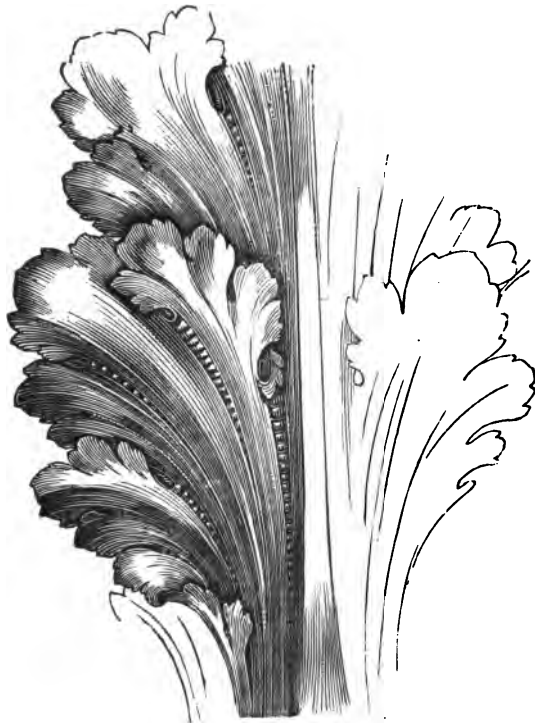

PLATE 4.

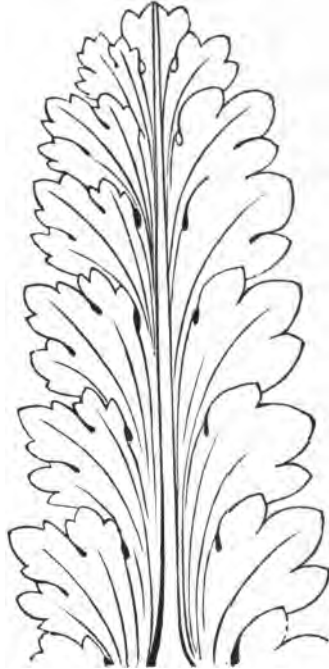
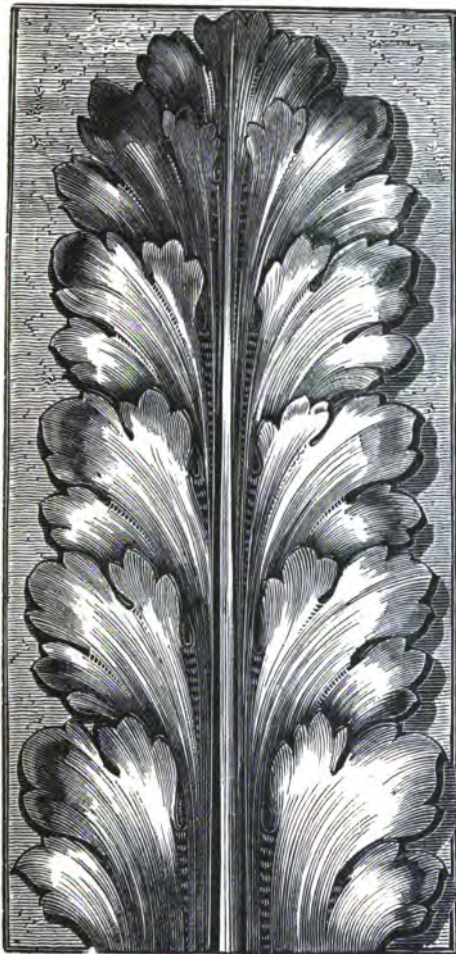
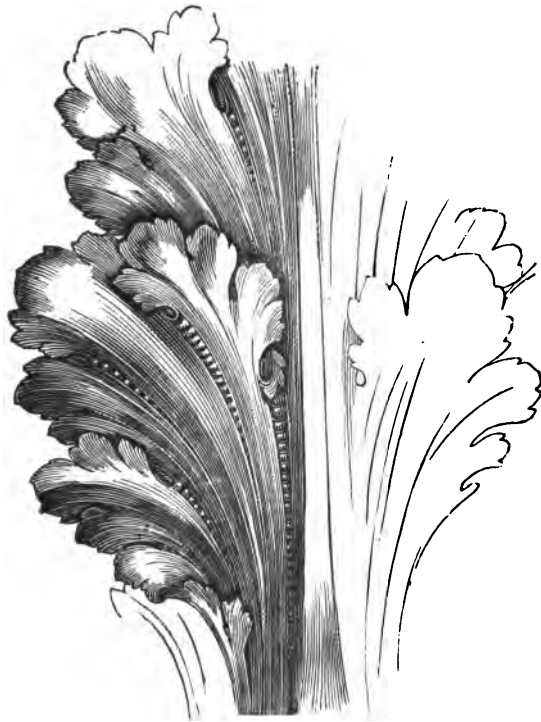

PLATE 5.



2 *
REESE LIBRARY
OF THE
UNIVERSITY
OF
CALIFORNIA

PLATE 6.



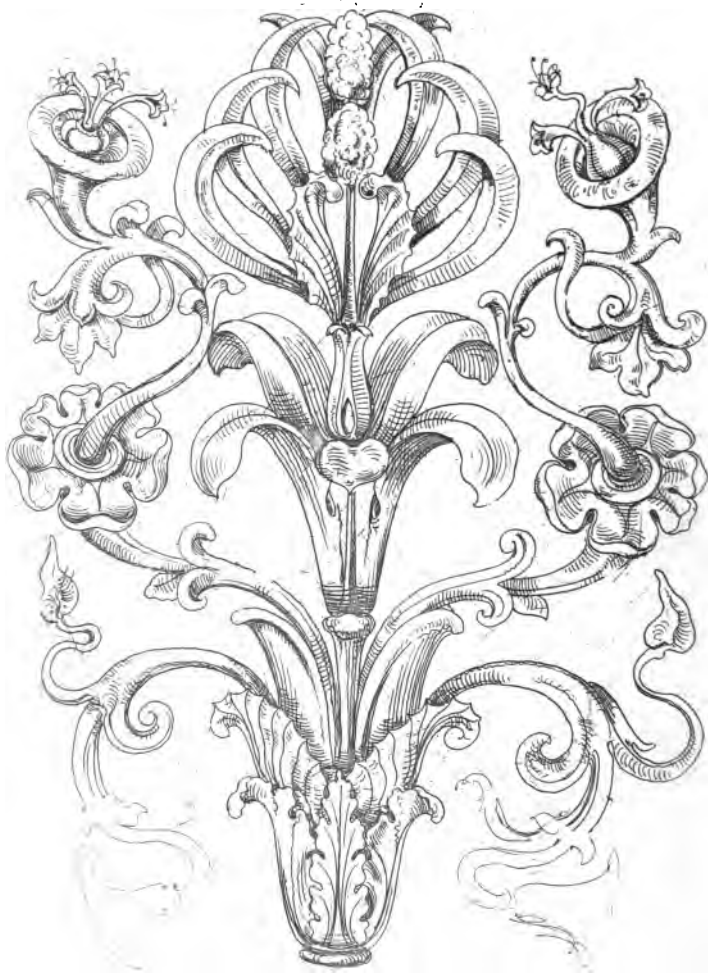

RULES AND PRACTICE
FOR
CURVILINEAR FOLIAGE.



WHEN you have gone thus far you have the first rudiment of an Acanthus leaf perfect in a perpendicular position, and the same rules must be carried through on the like principles for curvilinear foliage; I do not mean to state, that it is necessary for every design you make to go through those rules, and for this reason: after once or twice practising them you will naturally get them by art sufficiently to draw by hand,

C: for when the mind is once fixed on any object, particularly where benefit and interest are combined, nothing can scarcely ever obliterate it; still, I would wish to impress these principles, where the work is on a large scale; for however practised a man may be, he seldom arrives to that perfection, like *Phechotos*, who could very leisurely take a piece of chalk and throw the circumference or segment of a circle, in which way he pleased, without leaving off; and that was so well known to every person of note, that when he called upon his friends, he never required a card case, but would strike a circle to let them know who had called. I merely mention this anecdote to prove what practice will do, and a proper knowledge of fixing the hand will almost accomplish what I have previously stated, which I will illustrate, as nothing is, or can be more mechanical than the human frame, and the hand particularly, as will be seen in the following diagram; for when once you fix your wrist in a firm position, the carpus bones, or seven bones of the wrist, will act as a pair of compasses, and one

of the bones, properly named the *os. lunare*, you perceive acts on an apex, between the two

1. bones of the arm, viz., *b* the ulna and *c* the radius; for instance, you rest your arm on *c*, and through the elasticity of the tendons, sinews, and muscles, you are almost able to strike the annexed diagram, fig. 1, without moving the arm. You will perceive the principle by fig. 2; here I have placed an anatomical hand, holding a crayon, which shews by commencing at or about *d*, continuing your segment until you arrive at the diagonal line, *e*; from the point *a* you strike an arc of sixty degrees, and by extending your fingers from that point, you immediately form a concave line adjoining, or more technically termed a *cyma recta* or an *ogee* for mouldings. I allude in this manner that your freedom of hand is obtained on this principle by practice, for sketching off quickly any ideas that might instantly occur to you, naturally concluding should an architectural, or working drawing, be required, you would immediately strike your

moulding, and other curvilinear portions by rule and as there are so many publications on that subject, it is not necessary for me to illustrate at present those rules, at the same time every min-

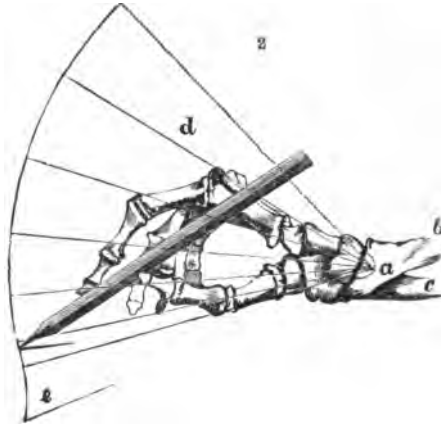

utia will be given that I consider necessary for different professions or occupations ; there is no occasion to enter more minutely on this point, sufficient has now been stated respecting the principle, utility, and freedom of the hand ; thus, I feel confident that with perseverance, and following a few simple but efficient practical rules

that I shall lay down, they will lead you into such facilities for drawing foliage, that you will never regret the study and perhaps labour it may have at first cost you. The following diagrams were struck at once, without taking the pencil off.

3.

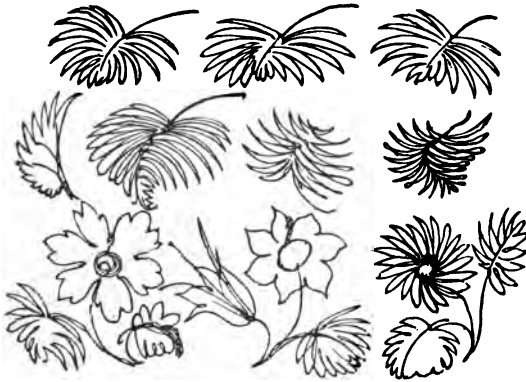

The hand placed in the position before stated, will accomplish the whole of the above diagrams.



ow to proceed with

FOLIAGE.

I shall com-

mence plate 7 with a rule for drawing a leaf to adorn the Corinthian or composite chapter, which is a very difficult thing to draw properly and gracefully; you perceive the contour of the leaf is kept as in plate 1, No. 1, *f* being the apex, *g*, of the leaf foreshortened; and again, by striking a segment of a circle, *e*, from the point, *d*, or centre of the perpendicular line, *d d*; the head curves are from two circles struck from *c c*, and meeting at the extreme point of *a b*; you then draw two mixed segments as at *a b*, preparatory to your proceeding with plate 8, which you are now prepared for. This leaf is drawn precisely on the same rules as plate 7; you will see the

PLATE 7.

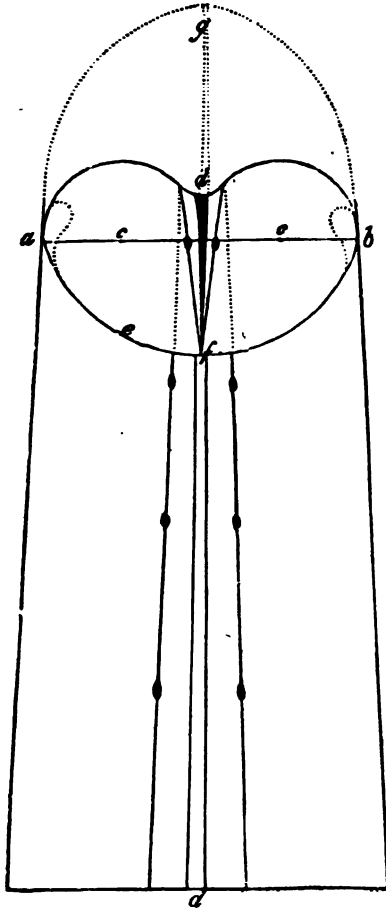
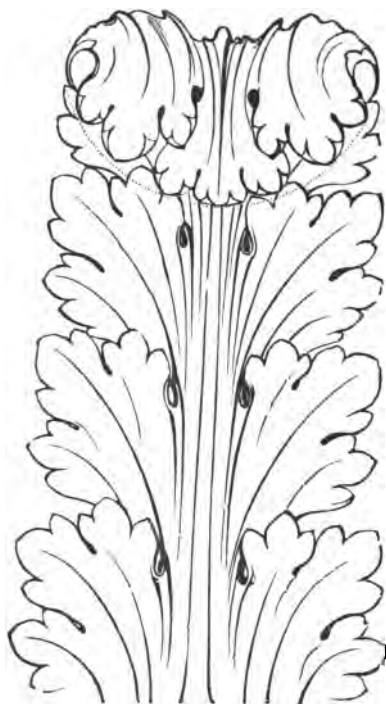

PLATE 8.



dotted line where the segment is formed for bending the head of the leaf, each part touching the pistules and startings, kept exactly ; this leaf I consider looks much better than plate 5, because, through the foreshortening, you lose a leaf, and it does not look so meagre, otherwise it contains the same number of raffles, but I shall now shew it completely finished, after just noticing a great failing in shading and colouring this leaf : you must always be careful to bear in mind that whatever distance the bend, either shallow or deep, is from the surface of your foliage, to mind your depth of shadow corresponds with it, as that enriches your drawing and adds to the appearance most materially.

I think plate 9 will give you satisfactory reason and proof for following, and learning how to draw this description of foliage, and I shall now explain the rules for putting that folded leaf in perspective ; supposing it were required to place it around the Corinthian or composite chapter, plate 10 will give you I hope sufficient explanation, at the same time

PLATE 9.



PLATE 10.

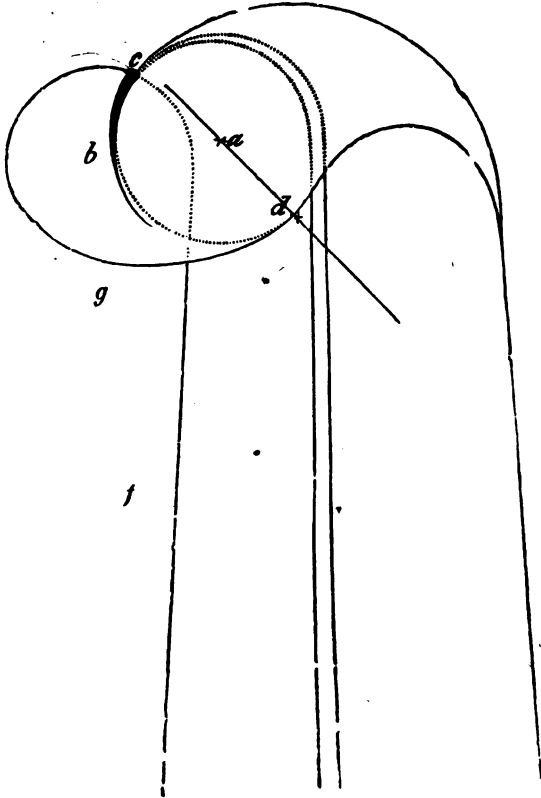

REESE LIBRARY
OF THE
UNIVERSITY
OF
CALIFORNIA

as explicit as possible. Strike a circle at *a*, which dotted exterior will give you how and where the centre stem falls in bending the head of this leaf, as at *c*; this is a very important part to be careful with, as the beauty of every description of foliage depends entirely on the gracefulness of the curves; *b* is the centre of another circle, which gives you the extent or distance for the off-side raffling, by dividing the circle, *c d*, into eight parts; the point, *d*, will give the head segment, starting from *c* to *e*, and from point, *c*, will give *d* to *f*; the line, *g*, will give the proper distance for the off-side of the stem, drawing it tangent to the circle, *b*. This figure is about proportionate for the first perspective leaf of the capital, and before the student begins to draw this order, he ought to be well acquainted with drawing various kinds of ornament and foliage, otherwise he never will produce a masterly performance, or be able to make any considerable figure in drawing so elegant a subject.

Plate 11 is another plan for turning the head of a leaf. Strike a semicircle from the point of

PLATE 11.

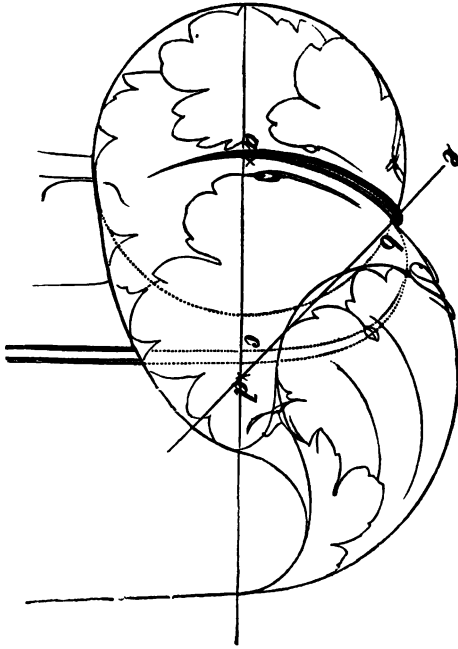

PLATE 12.



d, another at *a b*, shewing where the stem will pass through, and from the same point you get the segment from the diagonal line, *c*, to the exterior line of the circle, *d*, which forms the bending of the foliage. I see no reason now, if you have followed the foregoing rule, that there is any occasion for me to trouble you any more with the principles to obtain your pistules, &c., but shall now shew these leaves complete at once, at the same time notice to you, after the principle is thoroughly known, how and where you will have to deviate a trifle, not from any true cause, but to add to the beauty of the ornament.

You will perceive in plate 11, I have carelessly thrown in a sketch outline of the raffles, which in plate 12 you will find varied, on the extremity of turning the foliage. To prevent any misunderstanding of this statement, I shall first finish the heading of *one* leaf in one way, and secondly, in plate 13, complete a piece of foliage in as pleasing a form as I consider necessary. Having previously stated, that it is an object of the greatest importance for the student thorough-

PLATE 13.



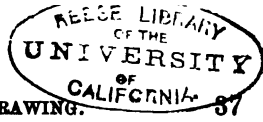

ORNAMENTAL DRAWING.

ly to understand foliage, before he commences this order, not only for the cap of the column, but he must be aware that there is no exact confinement, or to what extent, he is at liberty to decorate the other portions of the order, as the planseer or soffitte, which over-hangs the other parts of the capital for their protection, with different mouldings ; likewise the frieze, which I consider has given much more scope for improvement of design and decoration, than any other department of architecture extant ; for in ancient temples and edifices where this order was used, it seemed to be the chief fort of the architects to outvie each other in that respect, of which, previous to making any new design for that portion of a building, I shall give a few illustrations from ancient masters, not those following each others' footsteps, but where I consider there is a variety, novelty, and distinctness of form, and I think it will be acceptable, if only to compare with my own principles of design.

You must not consider that a leaf described in this form is only adapted to columns, but it

PLATE 14.

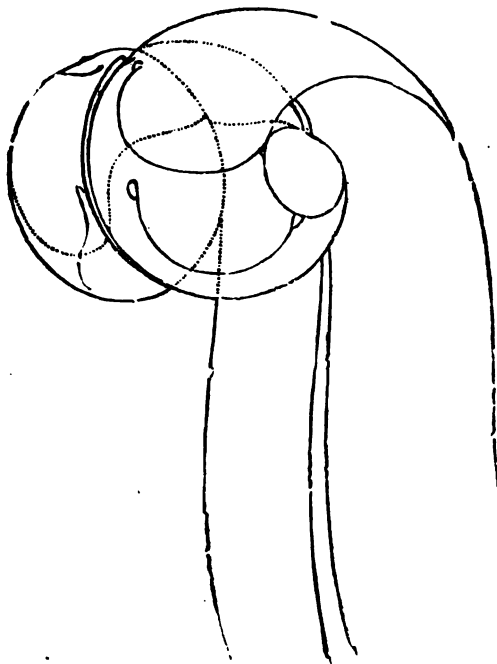

PLATE 15.



is very useful in forming cups for centre ornaments, and pillar bases; in fact, a variety of figures may be made from it, as I shall presently shew in outline, consequently giving the student the first principle of making design. Now, all I intend copying from, is plate 9, 13, and 15: suppose I require a pattern for a lamp-stand, or any other subject of the same description, I should form it thus; at the same time stating that, that is imperfect, but merely to shew the simplicity of the rule, and how easy when you



know the different turns of leafage, it will be to accomplish any design of that description of ornament,—namely, Grecian, as fig. 3. Plate 14 is a diagram of the leaf, plate 15 is a bent leaf, being the first variation from the perpendicular: this may perhaps appear very simple to you, but let me inform you, that on the swelling and con-

PLATE 16.



REESE LIBRARY
OF THE
UNIVERSITY
OF
CALIFORNIA

tracting of these curves depend your design, as a trifling alteration will give a decided variation of appearance, although you may take the same leaf for your guide ;—for instance, if you attend to the annexed diagram, I think it will be sufficient foundation for you to follow my principle of opinion ; here you see are a few forms for perpendicular starting points, or bases, and

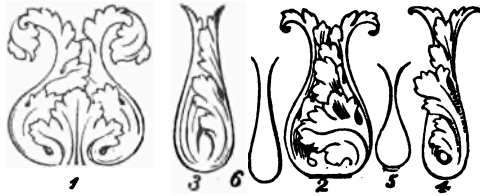

which, according to the height or situation of the object required, you of course must be guided, and which, in the following number, I shall treat more largely upon, as well as the other portion of bent foliage ; it would not be justice to rush immediately into designs, without first explaining the true utility of each foliage ; otherwise, I of course could soon fill a work with scroll, or what not ; at the same time leave you in the same dilemma, as many other publications of much

higher estimation to the eye have done ; particularly as regards the superiority of illustrations on copper or steel, but, as before stated, this is not my intention, utility is my principle, and I sincerely hope, with unremitting attention for the improvement of the student, I shall not only be serving myself in one respect, but shall be adding to the benefit, pleasure, and support of thousands.



CURVILINEAR FOLIAGE.



HAVING informed you of the necessity in managing your curves, I will now explain plate 16, which is commonly termed the eccentric leaf, and is very useful in many points, for centres, startings, and bracket ornaments; the position of which requires a trifling consideration before you rashly make a design; for instance, I will place a diagram where it is most useful, and how to arrange that

portion of curvilinear foliage: be careful never to place too many of any curved leaves together, otherwise you will cause a confused appearance, and nothing is so unpleasant to the eye of the common observer; and, for this reason, always allow a clearness of design—that is to say, an equality of ground as well as ornament; and then, if properly managed, there will yet be a richness; but be careful and understand me rightly when

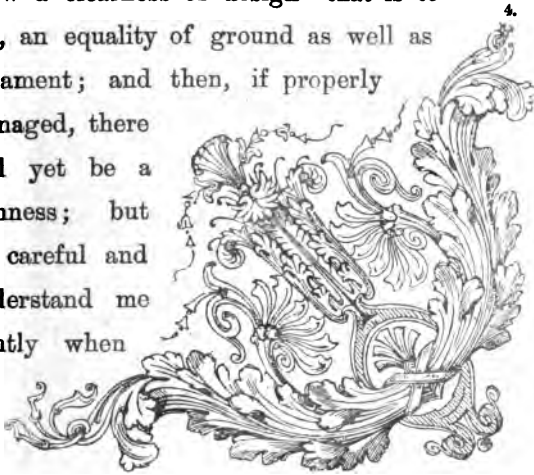

I say clearness, it is not to be meagre and scanty, but that of course depends on the taste and display of the designer, and which taste it is my intention to attempt to cultivate if possible, and, to prove, shall give three diagrams of the most convenient forms as regards utility. Fig.

4 is the exterior form for a corner, either for a frame, or may be made, with a trifling alteration, suitable for the decoration of a room, by running a line from angle to angle, or towards a centre, which may be formed again from the same leaf, as fig. 5; it is in this very point of decoration I would call your attention. You

3.



are, I dare say, all aware of what is termed Hogarth's line of beauty,—not that he was the originator of this line; but certainly wherever it is kept, not only in ornamental design, but in every other respect of the art, there is always a more agreeable feeling attached to general taste than when any other form is used: but to those who do not know what is meant by this expression, fig. 1, No. 2, is the form of it, or any undulating line whatever, where there are

no angles to be seen; and when decorations are on a large scale,—when I say a large scale, I do not mean that the ornaments are to be large, but, for supposition, a spacious room where decorations are from each extremity, or, in fact, almost every other description of decoration, as frames, chased borders, &c., be careful not to fall into the following error, which is a very prevailing one, viz., that of squaring your ornament; but I think when I give an explanation by principle, you will then agree with me. Suppose I have a border to design to a given size, either for a room, frame, or whatever purpose it may be required, my guide would be thus, as the annexed diagram will illustrate. Plate 17 you perceive is of an undulating form, and in which line I shall make a drawing, merely to shew the principle and utility of this foundation for forming designs, as will be seen by plate 17; here is a mere outline to shew how your ornaments are to be formed, and which suitable ornaments will be given in the course of the work, on a scale

PLATE 17.

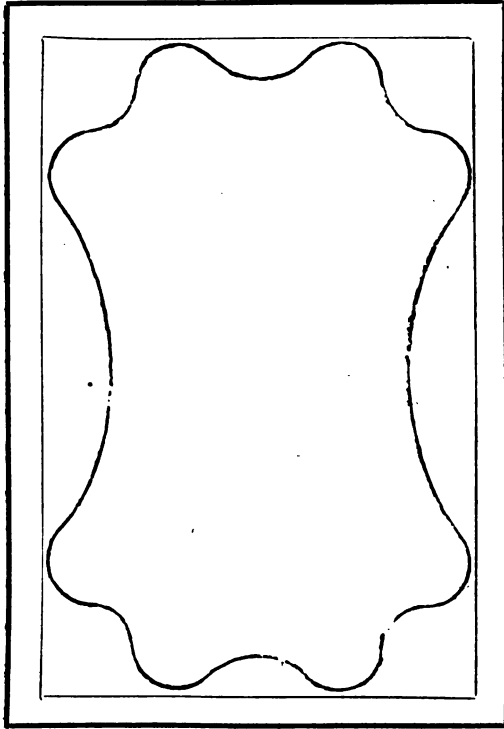

sufficiently large for patterns. In fig. 6 you perceive the centre and side ornaments like the form of the one in plate 17, and in making your design, you should lay that principle down and work to it accordingly, otherwise you may be like

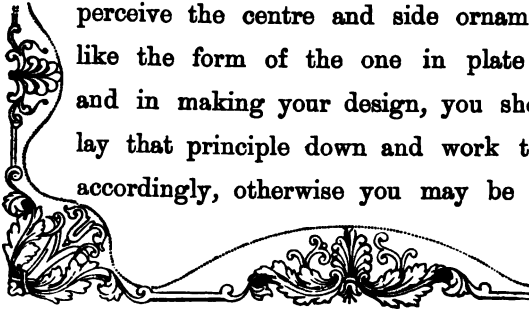

many over-talented draftsmen, who, when once they commence, they know not when to leave off, after making a good design, keep adding and adding, that the first idea is entirely lost; always bear this in mind,—when you have a good design, leave well alone; as it is not by a profusion of straggling leaves and ornaments that beauty exists, but as I before stated, clearness and equality without formality. I shall now illustrate another prevailing system, and which I think, after a little study from my observations, will be broken off, and a more pure taste be cultivated in the minds of all those whose capacity require the aid of ornaments; feeling confident in my own mind that it would

not only improve the freedom of hand on the part of other artists, but would likewise improve their taste for forming a basis for whatever subject they may require. Now to illustrate in opposition to my former remarks; I shall merely give another centre and corner, which will I am sure be a sufficient foundation for all the rest. You perceive in fig. 7, page 54, a square formality, which on being compared with fig. 6, you must allow is not so agreeable to the eye; and I hope, by this comparison, to give perfect satisfaction to your own good judgment, and, by practice, that such impressions will be made on your memory never to be erased; did I not consider this the basis of design, and being apprehensive that from the prevalent bend for ornamental foliage, not only of this description, but of others which I will shortly treat upon, and return again to this in some future number.

PLATE 18.





ears ago there were schools of design, but I may certainly venture to say, that of late years, there has never been in England an academy or school where these points of arts have been strictly adhered to, or true principles formed to train innate ideas; as I am certain the mind of man is like vegetation, which, without the immense care, trouble, and attention, that has been given to bring such articles to perfection, the luxuries and dainties of many could never have been supplied to the extent and gratification which they are at present; in this and many other points, no expense has been spared by those highly talented gentlemen who have taken the most prominent features in

PLATE 19.



botanical, horticultural, and many other branches of science; but never since our immortal Fuseli, Opie, Joshua Reynolds, and last, not least, Barry, has there been what is rightly termed a school of design; there has been truly, a school for painting, and copying, but never pushed so far as making students their own designers; and, why not? are they afraid, or what? nothing but copy, copy, and make pretty

7.



drawings and paintings, that this very ludicrous remark may flow from the parents' or friends' mouths:—*have you seen how pretty my son or daughter has painted his or her drawing; it is quite wonderful! what an excellent master they are under: he draws and paints so beautiful, he is quite a wonder.* And when this wonderful boy or girl ventures forth to the public, and has to compete with the proper trained student,

PLATE 20.



how fare the colours then? men of science and art, who are competent judges, are not to be caught by the glaring show of blues, reds, and yellows, but can judge rightly and feelingly, from a bold, free sketch, either in pencil, chalk, sepia, or Indian ink: in these, to look well, you cannot hide your faults,—they must appear, and so let them; then you perceive where you are in error. You are able, by proper study, not to wait for copies, but having studiously attended to all the different turns and finishings of foliage, natural history, and human figure; in plain matter of fact, let nothing pass you unobserved, retain all you see in your memory, either good or bad; you will then form, by careful attention to the principles of the old masters, a pure, unadulterated taste, which will never be forgotten. Of design, its chief element is correctness and style; its extinction, incorrectness, and manner. The first principle of correctness is the power of copying with precision and accuracy, studying each object of proportion with its relative attachment

PLATE 21.

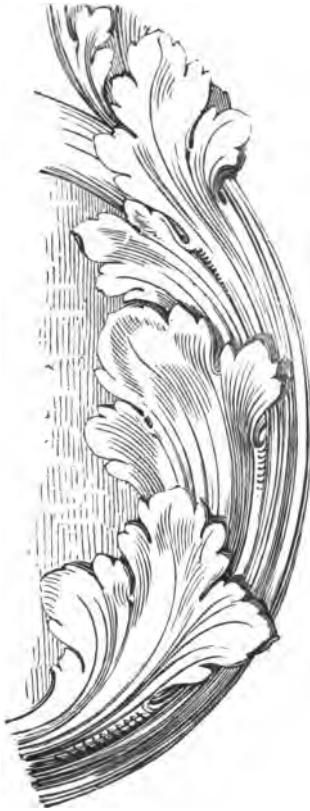

to others ; it ought to be considered of such importance that no person should enter as a student of any academy without his mind is thoroughly bent upon the former remarks. Did I not consider this the basis of design, I perhaps should forbear to speak, were I not apprehensive of the prevalent bend for design and reigning taste for every novelty of the Arts. I speak thus, knowing you do not lay on it all the stress required ; if you neglect the power of copying with precision, you never can acquire that of imitating what you may have chosen for your model. The two words *copying* and *imitating*, have, in one respect, the same meaning, but in the Arts it is very different, not only in meaning, but in its operation : an eye geometrically just, with a freedom of hand implicitly obedient, is decidedly requisite for the former, without choice, selection, amendment, or omission ; whilst choice directed with judicious taste, constitutes the essence of imitation ; and, by perseverance, raises the once humble copyist to the rank of an artist, which appellation, I am

sorry to say, is very much abused, for every one that can use a paint brush a little and copy as much, must needs be termed an artist, being little aware of the labour and study he for years must persevere to obtain, not only in the art of drawing and painting, but he must be well versed in all histories and passing events; in fact, his mind must be a library, not only as regards the time, or in whose reign he is referring to for a subject, but the very costume, actions, and deportment as well: the science of optics ought to be in his full possession, that he might know how to distribute his lights on a picture; also a knowledge of the effect of gases contained in the atmosphere, so as to counteract them with his different drying oils and varnishes, to prevent the rapid destruction which too often takes place on the different portions of a painting; these and a few other little minutiae, which are to follow, is the basis of design; and following in those steps, you, I have no hesitation in saying, will arrive at that state of perfection in the Arts to repay all your labour. Be careful to attend

PLATE 22.



to the few following observations, and then I shall return to the former illustrations. Every thing deserving the title of beautiful, and every grand object, assumes an outline of definitive character; the former in undulating lines of elliptic curves, and grandeur in angular dispositions of figure lines of motions, assume a curved direction; in combining straight lines, so as to please the eye, they must be on a radiating principle; our eye not only receives that form as pleasing, but, at the same time, prevents any geometrical form to detract the beauty of the above figure; and when lines are placed parallel to each other, they have an appearance of a flight of steps, or pile of rods, and have a very opposite effect; upon the former principle it is that the rays of the sun and rays of light generally are so attractive and beautiful. It is from this circumstance that right lines drawn in an inclined position to the plane of a picture, derive an interest from the angles engendered through the imagination. Combinations are like numericals; many of these forms placed

together with judgment and discretion, will attract us from the larger proportions of beauty that meet the eye at once,—like a beautiful head of hair; a single hair, however gracefully bent, cannot impress us like an entire lock, nor will this single lock look like the whole upon the human head: we owe to combination and construction that pleasurable feeling denominated beauty. No person is allured with a single object, but a thousand, or even a million immediately arouse our anxious notice; thus, my instruction and previous diagrams of elliptical and circular forms exhibit, by a continuity of curves, the greatest approach to beauty of any of its predecessors. Even curved lines of a convex and concave form, drawn at random, without expressing or forming any sort of figure, please our eye much more than all right lines, however they may be distributed; quantity and variety are absolutely necessary to the production of perfect beauty; equalities being unfriendly to all symmetry which accord with nature. I think sufficient is treated at present

on design, and will now continue my explanation on the previous plates.

Plate 18 may be formed into either a concave or convex leaf, in the throwing off the extreme end or curl; care is required in this simple point, as the freedom entirely depends on the manner that you carry the stem. This piece of foliage is not only useful as a portion of adjustment to a running scroll, as the following diagram shews, but will also form a good

8.



starting point, if aided by another convex curve, as fig. 8; it likewise may be used in another way, for a centre if necessary, as fig. 9; and by a trifling alteration in many other figures. Care in drawing or carving this leaf, for instance, and a very important one it is, being careful

not to have the back and front of this description of foliage both alike. Should I have the



9.



carving of the front of the following figure, what will the appearance of the back be?—now, mind this, it is not only attending to the accuracy of drawing, but greatly to the effect, as fig. 10. Through the rotundity of the

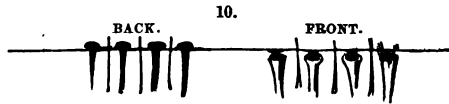

pistules, a high light will fall on the face, and at back, it being hollow, of course they will be dark,—almost black: to prove this, in plate 19 I have given the back-view of the leaf, and the difference will be observed on the turning of the head; the ruffles, instead of passing over as they do in the front, you perceive it passes under, which has a very different appear-

PLATE 23.



ance; this is chiefly needed in design, where you have a confused group; in this case, of course, you must see the back as well as the face of the foliage, and on that point the variety of effect upon natural causes is the very thing you have to pay the greatest attention to, as that gives the whole life to your picture.



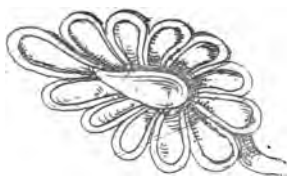

CURVILINEAR FOLIAGE

CONTINUED.

Now to proceed to plate 20. This is a piece of foliage seldom brought into play; why? because of the difficulty in producing the true appearance; it is generally termed the ogee curve, and requires great ease and knowledge of foliage to bend it properly; in this you will observe how I have kept to the principles referred to in plate 18: you perceive in the lower part, that the pistules are black, the upper ones light, and by that, it produces a different effect, than if I had kept it all one colour; of the utility of this, I shall treat hereafter in a more efficient manner, and by those means cause a greater variety of foldings and twisting than is generally produced, at the same time break that flat and dull appearance which too often presides in de-

signs of running scrolls, &c. Plate 21 is a very important part in several portions of running scrolls for friezes, and many other departments of borders, it is usually the most prominent feature beyond the boss or centre; how it should be introduced is shown in the following diagram, page 78; you will there perceive by the continuation of its own figure alone, it will form a very good running scroll, and partakes more of the Roman than of the Grecian leaf, the varieties of which you will perceive accurately drawn further on in the work; at the same time, I think you have almost sufficient, and I may say all the general turns of foliage. But previous to my leaving the turning of leafage, I will introduce the Acanthus, comprising of every turn that can reasonably be given, from which you will be able to select all you may at any time require, for what is generally termed *pickings*; for however proficient you may be in designing, yet you cannot sum up every thing that may be brought into action in your mind at once, and by that reason, as I have before stated, let nothing pass you un-

observed ; at the same time, possess yourself with as great a collection as you possibly can, I do not mean of expensive, or what is termed rare subjects, as that very sound will, when a valuable print comes before you, draw more attraction and attention from you than a common penny print ; but let me tell you, that I have known many who have obtained a grand collection of designs, &c., for the trifling sum of ten shillings ; in fact, I have myself, at a stall and different places, oftentimes bought more to my advantage for a few pence, than if I had given half-a-guinea for a rare specimen of engraving more than the design ; and why ? because my eyes are upon every thing that I pass, or that passes me ; and it is by attention to this I know what I do. Feeling this much, I consider myself no more blessed than my fellow-creatures, and am certain if they follow this piece of advice, they will be able to do as I have done ; *yet not feeling myself to know one half of what I hope to know and arrive at ;* for I am never satisfied with saying I can do as well as another ; that will not do, I wish to do more and better than

another ; and while you and I are thus striving, it not only renders the study pleasant in itself in one respect, but will, in course of time, place you in circumstances generally enviable to those who have neglected their studies.

In a portion of my collection I have copies from the finest specimens of Roman and Grecian sculpture that have been executed, from which I intend giving you the several principal leading points, and its variety of characters ; and by careful attention to them will insure success. Should you in the course of study have to lay your drawings before professional gentlemen or travellers, by whom they may be recognised as true Grecian, Roman, or other ornamental foliage, do not imagine that all ornament must contain foliage ; I can execute a great number of designs and yet not have the least portion of leafage attached to it, and this description generally runs in the Grecian ; although at the same time there is a foliage for that description of decoration, and which is very different from all others. The different characters of ornament, I may say, are

as others have done from much more scientific men, and whose affluent circumstances have placed it in their power to travel and study when I could not; but trusting I have collected and seen sufficient at least, not to misguide you, and to this end, the following paragraph is very appropriate, and at the same time, I think no harm in noticing it, particularly when it is obtained from such an author:—

“ From small beginnings, great conditions rise;
Act well your part; there all the honour lies.”

POPE.

Not that I have risen to great conditions, *but* I recollect about seven or eight years ago, when in my struggling moments to achieve at something I had the conducting and designing of the ornamental department of a work, entitled the Album Wreath, for a firm in the City; many appeared before, but this was to surpass all; and, as it often happens, when we strive to do our best, we are conquered by an over-anxious feeling, and our mind is entangled and confused with ideas, that a jumble of objects appear to our eye, and we know not which to choose; this was the very case with

me. I tried borders, flowers, &c., but nothing gave me satisfaction, yet my employers were contented with each sketch, and they knew not which to choose. At last, waiting on a friend one day, whose children were playing in the parlour, one of them held up a piece of looking-glass and simply said to the other, "let this be our mirror." That very word was all I wanted; I immediately took my pencil, and while waiting, formed the rough idea, thinking all the way home, how to fashion that and many other portions together: when I shewed the design, all others were thrown aside, and this one immediately commenced and finished as a frontispiece; and reckoned by all who saw it, to be the master-piece of Ornamental Typography, and my employer had the whole of the work; and this was all through, as I before stated, immediate attention to all that passed.

I will now return to the explanation of my former plate, and to one of the most important portions of ornament, be it in whatever style, character, or era, it is for, viz.—freedom. I certainly have previously mentioned respecting the

figures and curvilinear forms necessary to be observed in designs, but I will now treat more fully on the subject, and I hope sufficient for your guidance hereafter. This point will refer to plate 22, here I have given a mere outline of what is termed the volute, or ram's horn turn of a running scroll, but it does not always partake of that form; I may use the following, figure 11, the centre of which has the appellation of the ram's

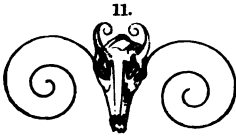

horn. You see by the foregoing plate, 22, in the centre of the foliage is a

dark line, which line, when you commence forming design, or making a copy, is to be your leading feature or basis, and that once done properly, you can always insure freedom in your positions or decorations; in this case, as I have before stated, nothing should appear to partake of the tendency to an angle; for this reason, let your drawing be ever so richly executed and carefully finished, if there is a fault, it is to that point alone that the eye will be attracted, because if there is a circular figure to view, the eye will

naturally carry itself around that figure, if it were a yard long, and drawn on a small scale; but should there be any breakage in the curves, it immediately breaks the traversary orbit of the eye, and that very error is retained in the memory if the eye could see the whole yard length at once, that would *still* be the most prominent; to prove which I will give three small illustrations on this subject, and then finish the explanation of plate 22.



Fig. 12, you perceive is of a true running undulating form; fig. 13 is of the same description, but broken and full of what is termed shoulders,

glyphics, birds, insects, and beasts,—all of which they have worshipped as idols. The Grecians followed them narrowly from the first description, and instead of having straight stalks to support their cups, they have formed them into volutes, making the cup, or flower, the support of the stalk in many instances, instead of the stalks supporting them. This will be seen in plate 26, which I shall treat upon presently, as well as to prove my foregoing remarks, that all scroll work does not contain foliage. It is to this point the Grecians, in my opinion, as well as many others, excelled in beauty,—for their basis was clearness and regularity; and this is a point that no other character or style can boast of; even in their capitals and pilasters, there is more delicacy and clearness than in the Roman, whose forte seemed power and might. To prevent any mistake of my ideas, I will explain, as the plates proceed, the number of starting points known to the Roman, Grecian, and Arabesque, being about eighty-five different descriptions, each

having its particular use, name, and character ; this to many may seem absurd, but those who think as I do, will agree with me how essential it is that this description of study should be thoroughly entered into previously to their attempting design. I once knew a young man who termed himself a designer, and so he *really was*, what I term an original designer, for his chief forte was to jumble almost every description of foliage, &c., into one mass, which was certainly perfectly original, but very ridiculous ; and I would have you pay great attention to this point, for whatever style of ornament you commence, adhere to that, and no other. If you compose Roman, use Roman ; if Grecian, the same. It would be rather ridiculous for me to erect a Grecian temple with Gothic pinnacles, or a Gothic structure with Grecian ornaments. I think you will now see how necessary it is that you should give your mind more to these particular points, than you have ever been taught before, or shewn the necessity required, as regards attention to this portion of the arts.

In the first plate of starting points, I have commenced with the most simple forms used, both with and without their basin and cup.

The annexed diagram, fig. 16, is one of the most simple forms possible to be used; and fig.

16. 9, page 64, of the most simple in general use. The cup, or flower, on the same line with fig. 1, is its proper attachment,



but both can be used separately;—this is termed the lily cup. This starting point is chiefly used in what is termed modern Grecian. Fig. 2, is the second description of lily, used generally as a double starting point; that is to say, confining the two stems running transverse to each other; the basin, or flower, behind is the portion to be attached to it, if required; both of these may be used separately: and, previous to my leaving this figure, I will explain its advantage over the former one,—You will perceive at the base of the bell a quirk, or opening between that and the stem, which, in bas-relief, has a very powerful effect, as the annexed figure will shew. Figure 3 is another

description of cup, called convolulus-head, this has its cup attached, and has a very pleasing effect when well executed. Fig. 4 is the woodbine, or honey-suckle, and daisy cup ; the hinder

17.



part in juxtaposition, you see is of the simplest form, represented in fig. 4, and is chiefly used in a centre running scroll of three portions, and formed generally to break the traversing of the eye from its chief point, which is usually the centre scroll, boss, or finishing, and ought to be the most commanding portion of a confined scroll, generally under shop windows, as you will perceive in plate 32 ; here I have given the framing of the window, and the department where such ornament is useful, not only as a decoration, but at the same time useful, as it affords light to the kitchen, warehouse, laboratory, &c. below, and answers much better than

the straight bars. I have given in the same plate, three designs for that purpose, and intend giving, as the work advances, a variety of illustrations for that, and every other department where decorations are required. This is done

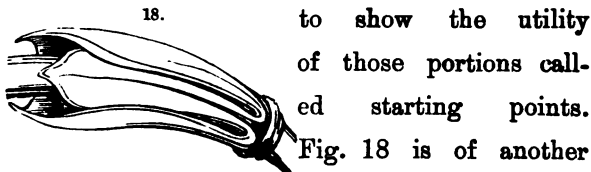

to show the utility of those portions called starting points. Fig. 18 is of another simple form, termed the crocus-head, a very useful portion where you are confined in space, and where castings are required for balustrades; in designing for that department, you must be very careful not to have much straggling work, but close and full, to prevent as much as pos-



sible the chances of different parts being broken off, as fig. 19 shews. I will now illustrate fig. 20, termed the bell-head, seldom used in the body of scroll work, but is the starting point for the little cups and small springings of design, as

you perceive in the annexed figure. Here it is given slightly, showing you what I mean by

20.

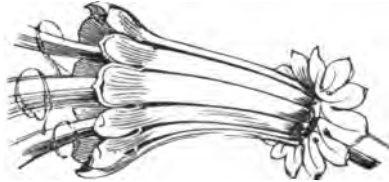

small springings; I shall now refer to plate 26, where you will more clearly understand my previous remarks: fig. 1, you may say is formed



by the double lily and the convolvulus-head, forming a very good frieze round a

room, or for chased edges and rims; the foundation of this is taken from the Cymatium, in a temple at Parma. Fig. 2, in the same plate, is from an antique bronze, and very different from any at present in general use; the corded reed at the top, and the egg and button at the bottom, is a very great improvement to the effect of the moulding, as well as the novelty of the different ornament between each division

GRECIAN

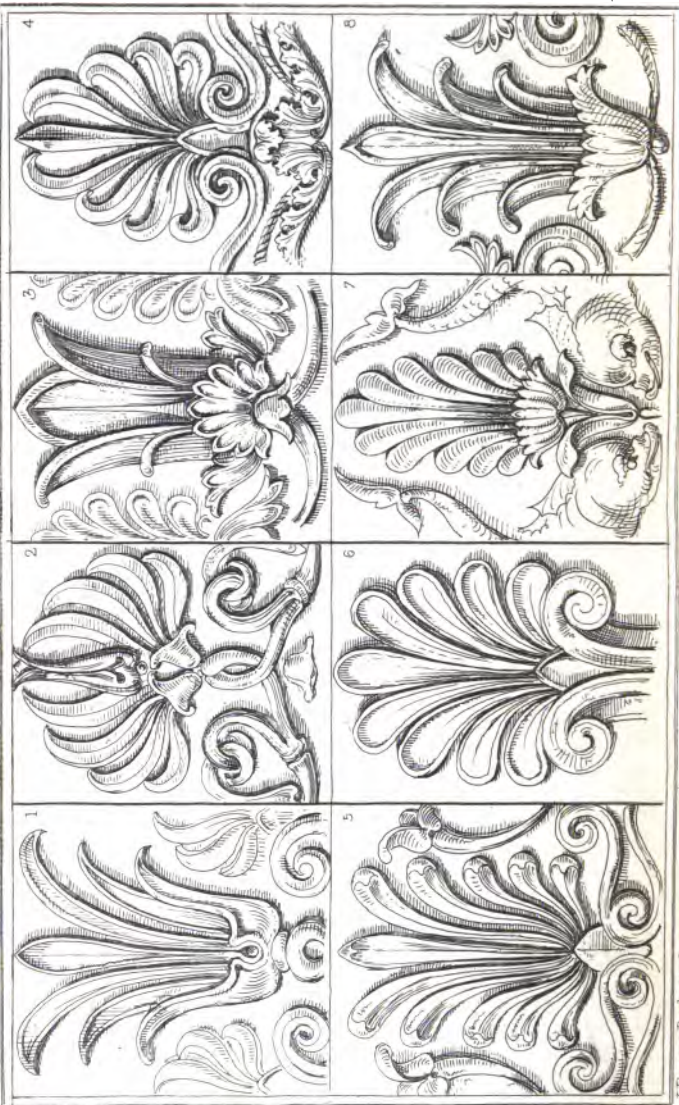

L. Page, Del et Sc.

of the ruffling ; the section of this is shewn in fig. 22, which is very symmetrical. Fig. 3, in

22.



the same plate, is likewise from the temple at Parma, as fig. 1, and shews a portion of a frieze ; here is introduced starting points, only formed from the Grecian dock leaf, as shewn in plate 27 ; likewise the small springings as before-mentioned, and of which the Grecians were very partial, and that to a particular extent and description, of which I intend giving a plate, containing all the chief characters they used ; in this instance, it seems as if the cups contain the stem, which are in the form of volutes, instead of the stems holding the cups, as with the Egyptians, as the following figure shews. Plate 27, represents the three foliages used by the Grecians ; fig. 4 is seldom brought into play in running foliage, but confined chiefly to the chapter of columns, and fig. 5 and 6 are both generally used in running scrolls, cups, startings, and columns ; plate 28 brings all these into

play,—the semi-honeysuckle, lily, lotus, and dock-acanthus, and I think is very well adapted for the purpose designed. By continuing it along a cornice, or frieze, it has a very rich and imposing effect; it is spread rather more than the original, yet the proportions are good,—you perceive how equal they have made the appearance; you cannot see the ground-work, but the ornament itself imposes upon you im-

23.

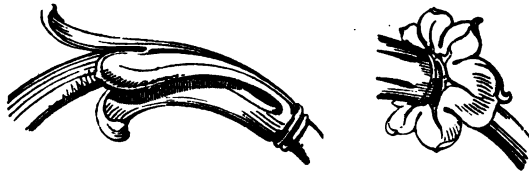

mediately; and when looking at the ornament, it is not so confused, and the ground appears at the same time. I do not recollect any so symmetrical among the specimens I have ever seen. I have in a work, from which I have selected a few of my ideas, some splendid specimens of the Roman, which, in the following number, I intend to illustrate, to show the overpowering richness their designs have over the Grecians.



Fig. 6.

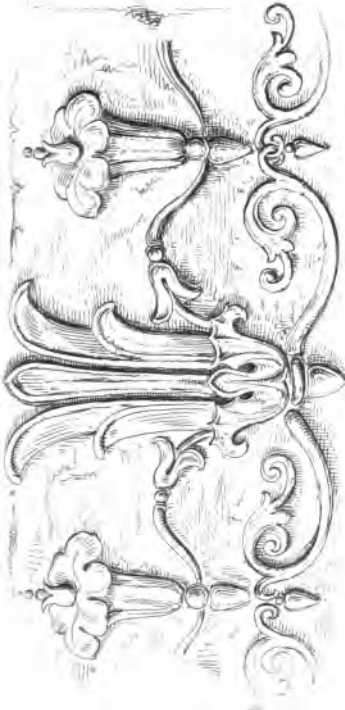
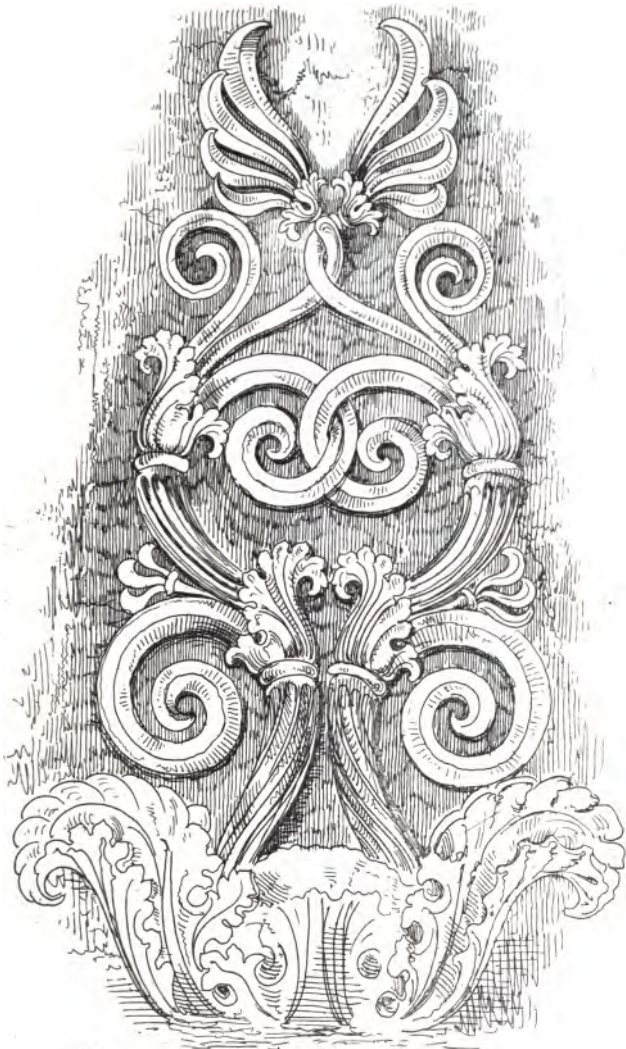

Fig. 7.



Fig. 8.

Fig. 8. 1870.



I.P

GRECIAN

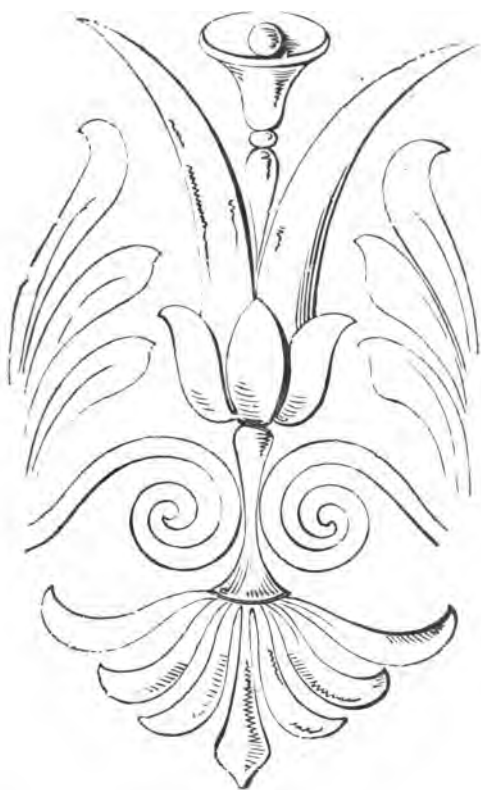

GRECIAN.

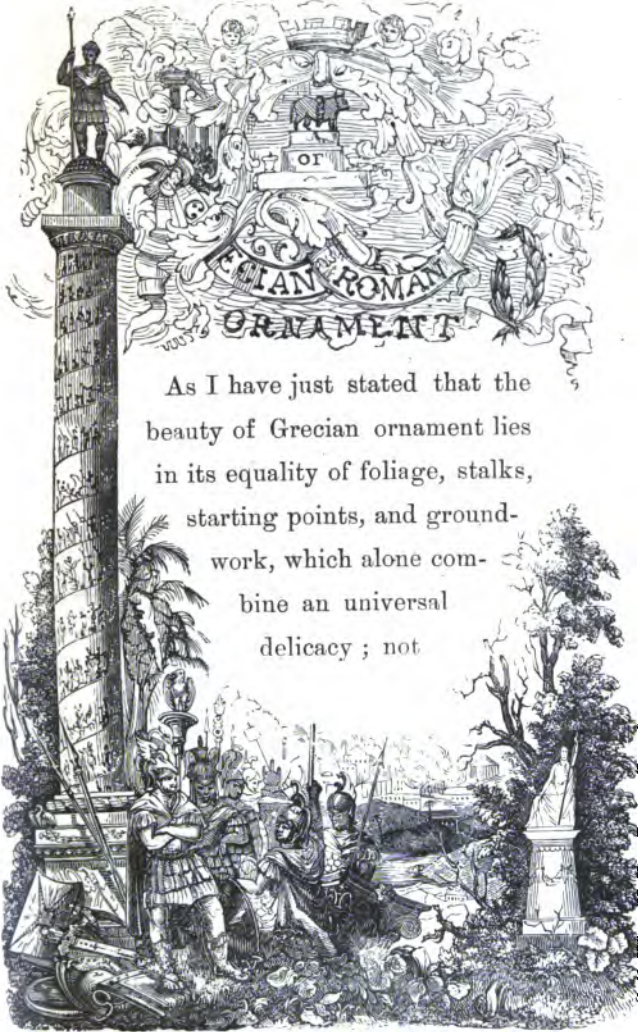

as with the Romans, whose delight seemed, in many instances, to obtain an overpowering richness with their designs; in fact, so far as to cause an unintelligible confusion of flowers, foliage, starting points, animals and figures: to prove which I will illustrate a portion of a Roman frieze, taken from the Temple of the Sun, plate 37, this being a competent part, (which of itself is a complete division,) and, when joined together, as here given, forms the whole of the frieze around the upper portion of the temple. This foliage you will perceive is of the Acanthus order, but of a richer and different description than I have heretofore illustrated or spoken of. You perceive a greater number of ruffles, and more closely and irregularly serrated at the edges than the Acanthus Mollis, or Spinosa; at the same time there is a much greater depth allowed by them from the centre stamen, or stalk, for the pistules, as you perceive in the next diagram, fig. 24, where it is more closely delineated. This body of the leaf seems to be formed of a number of stringy fibres,

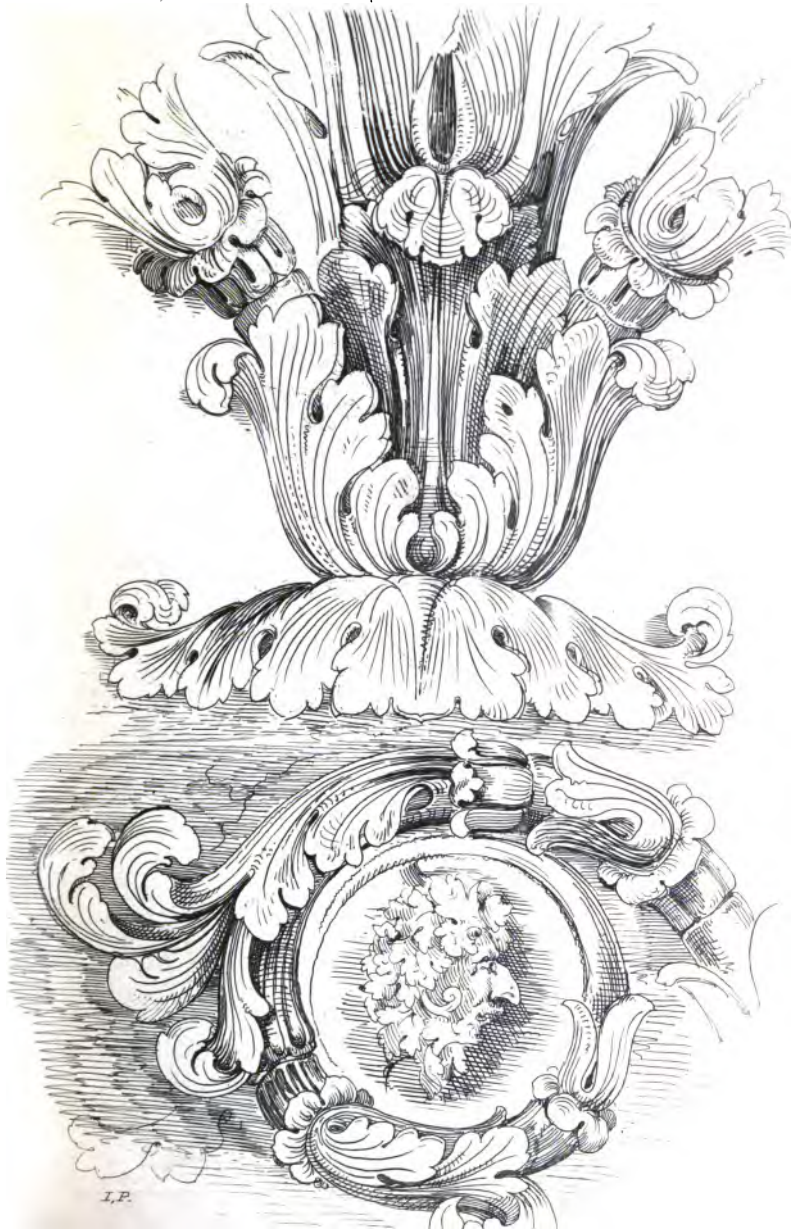

J.P.

PLATE 37.



Outline division of one of the circular portions of the frieze around the Temple of the Sun.

which, when properly sculptured, drawn or modelled, gives it that richness I have before described.



berries, or other small round fruit, which agrees with the account given by *Theophrastus*. I shall shortly delineate a few principal starting points alongside of the Grecian, giving you, at the same time, a decided and clear proof, how careful you should be in keeping character to style; in many instances, I have seen the most elaborate designs and elegant formations spoiled by these combinations; the original plans

On referring to the illustration in plate 36 fig. 1, you will perceive my former observations brought into practice: here you see are the starting points, composed of pods, containing



Fig. 2, 3, 4. ROMAN BOSSES, 5, HANDLE TO AN HERCULEAN LAMP, THE REMAINING FIGURES ARE GRECIAN SPRINGINGS

GRECIAN FRIEZE FROM THE TEMPLE OF APOLLO



GREEK FRIEZE FROM THE TEMPLE OF APOLLO

being laid on sound principles, and the rich ideas of the designer spoiled by this apparent sim-

25.



ple, but yet glaring fault.

When you reason with yourself, compare the delicacy and richness of the Grecian brought in contact with

the massive Roman style, you will then observe the necessity required in calling your attention to this particular point; and I sincerely hope, by perseverance, that you will make the necessary alterations in your mind, (*should you have possessed them,*) the result would be to me,—all I have wished for,—*your improvement.*

In plate 37 is another description of frieze, from the Torre de Nerone, at Rome. In this you will observe the combination of foliage, animals, and figures. These friezes, I have no

doubt in stating, could they be read, would speak volumes ; for I have no reason to suppose that such would be introduced without a why or a wherefore, and I believe that such has been spoken of before in books that I have not been able to obtain, whereby I might give you that information, which it is my earnest wish to do ; nevertheless I will assist you all that lies in my power, by giving you a series of those that have been executed on baths, palaces, or temples. In plate 38 is a frieze from the Arch of Titus ; this is composed of figures and animals alone. Here I can describe the reason for this, and a just one too, being led to believe, and knowing from ancient history, and that valuable and sacred volume, the Bible, that their chief principles of carrying out the solemn rites of religion was by strict adherence and attention to their holy altars, temples, incense burnings, and the offering up of sacrifices. These ceremonial rights were attended with great reverence and splendour ; this being adhered to with such rigidity, is the reason that processions



PORTION OF THE FRIEZE FROM THE BATHS OF DIOCLETIAN ROME



D^o FROM THE ARCH OF TITUS ROME

I.P.

and sacred rites were introduced in their exterior and interior decorations. I shall now give you, by illustrations, the necessary articles used on those occasions, and which were sculptured on the Arch of Titus, and many temples at Rome. Mentioning this topic is not entering into theology; far from it: but, you are all aware that, in the course of studies and occupations, no one can tell how, or to what extent his capabilities may be called into action: so, for this reason, I consider it my duty to call your attention to this point. I have previously said that, for whatever era or style you are decorating, illustrating, or designing, strictly adhere to the articles, costumes, and manners of the time. Suppose you are designing for Roman decorations; you should endeavour to obtain a thorough knowledge of ornamental flowers, different kinds of moulding, weapons, dresses, armour, and sacred utensils, in case you should have occasion to introduce them; as these tropical introductions, when properly managed, give a very pleasing, instructive, and

lively effect to the model, sculpture, or painting. All these principles were, I have no doubt, taken from the Egyptians; which, for your instruction, I shall enter rather minutely into, as far as regards its application to drawing, &c. But first I will explain the whole of the Roman utensils, used for sacred purposes. The golden candlestick, or more properly speaking, candelabrum, or lamp-bearer, (which is represented, with various other articles, in plate 39,) we are given to understand, was of pure gold; and, according to *Josephus*, was of hollow tubes, or brackets, and was composed of seven branches; one in the centre, and three on each side; each bracket, or arm, was joined in separate compartments by lily flowers and figures, in the form of pomegranates; and being composed of about seventy different pieces: at the extremity of each arm were seven golden lamps. Many fanciful representations have been formed of this lamp; but my illustration is from the Arch of Titus. Some historians have asserted that it was

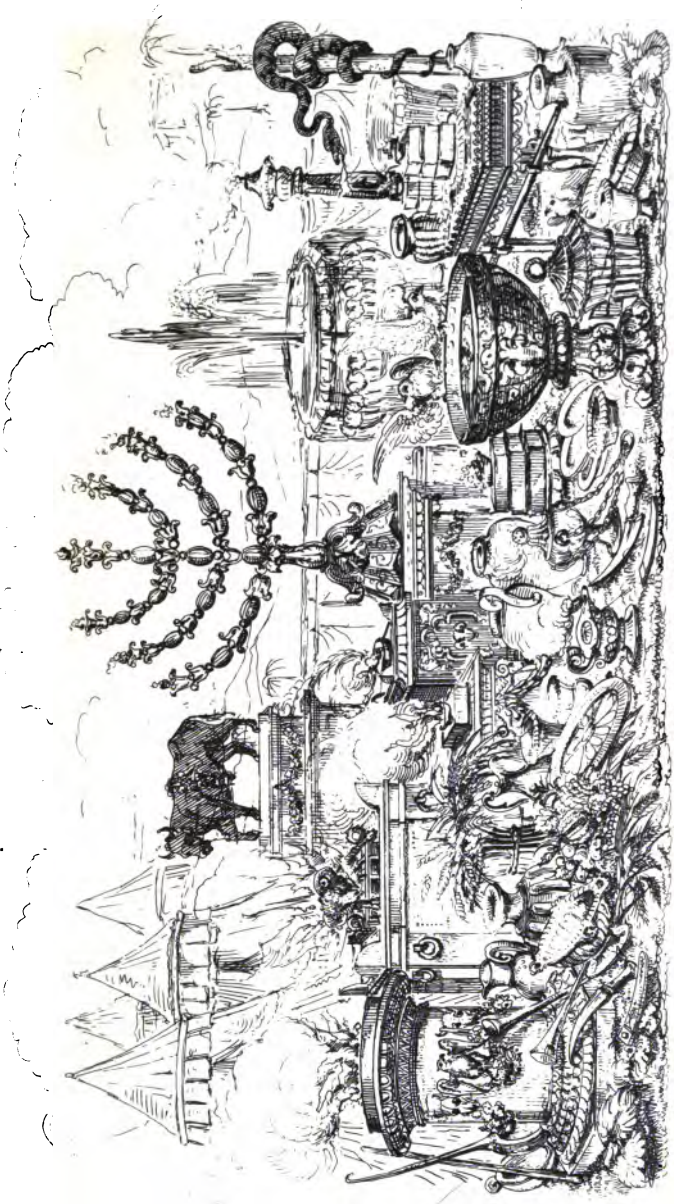

UTENSELS FOR THE OFFERINGS OF VARIOUS SACRIFICES

J.P.

illustrate the antiquity of this practice, I need only refer to the instances of all the Hebrew patriarchs; but persons, whose circumstances could not produce such oblations, might offer either a bullock, a male of the sheep or goat, a turtle-dove or pigeon. When the animals were killed they were flayed and opened, their intestines taken out and washed, the feet also were washed, the back bone cleft, and the carcass divided into quarters, and all parts exposed to view: this sacrifice was then salted, and the whole, except the skin, consumed on the altar. Third, meat-offerings were carried out by vegetable products, and preparations of meal, bread, cakes, ears of corn, parched grain, oil, and frankincense. *Theophrastus* states that little figures in paste were made by the Greeks, mixed up with oil and wine. The Greeks and Romans did not consider an animal offering complete without the above-mentioned articles were placed upon the head of the victim while still alive and about to be sacrificed. Fourth, the sacrifice of peace was by offering a lamb,



and other animals as before, only males and females might be offered, but males alone in the others. Fifth, sin offerings:—when a ruler sinned the offering was a ram; a private person, a sheep or a goat, two turtle-doves or an ephah of meal: so that scarcely any could be deterred by poverty, when his conscience prompted him to the confession of his sins.

I think these are sufficient observations upon this topic to enable you to illustrate all you may require in that department; and I shall now refer to Roman and Grecian arms.

By the insertion of these articles, either for war, torture or triumph, is not entering into any very detailed history, but as such things are universally required in drawing, or design for trophies and other emblems, to illustrate ancient history, or to adorn the different compartments, as well as the friezes for triumphal arches, or columns; in fact, almost every department of the arts, where ornamental work is brought into requisition, a thorough knowledge of this description is highly necessary, and it is my in-

tention that nothing shall pass me unobserved, if possible, that is requisite to be introduced for utility of decoration. I shall give a compilation of Roman arms, as halberds, shields, helmets, standards, flags, battering rams, and other implements, which contain the most prominent, and those most universally known to be used, and a short history of their origin will, no doubt, be acceptable.

"And oft conducted by historic truth,
We tread the long extent of backward time."

THOMSON'S SEASONS.

I am aware, as well as you are, no doubt, that there are many Grecian and Roman histories, but very few, if any, that will bring to an apex those points suitable to this work, and leading facts required for the arts.

The earliest establishment of arms, under a regular government, was introduced by the Egyptians; they communicated their discoveries to the Greeks, who improved upon the instruction of their predecessors: from thence to the Romans, from whom the other European nations

received the first ideas of the arts, and which have been in a state of improvement to the present day. As warfare was the leading character of the Romans, it is to them we owe the origin of crowns, triumphal arches, columns, and trophies. Of the Roman habit and dress, would be useless for me to enter into, as it would entail more on me, than I consider a work of this description requires. It was found necessary to distinguish those who had signalized themselves by some more valorous deeds than their fellow soldiers, not as in the present day with money, but with coronets or crowns; the original of which was worn by the high priest, of a plain gold fillet placed upon his forehead, and tied behind with ribbon, which was taken off for a certain time: to assume the appearance of one in mourning; afterwards they wore two bandelets; and, by degrees, they took branches of trees of various kinds; subsequently they added flowers; and, at last, there was scarcely a plant of which crowns had not been made.

The Romans had various crowns which they distributed as rewards of military achievements.



The oval crown was composed of myrtle, as shown in fig. 26; this crown, or coronet, was bestowed only on such generals as had the honour of a triumph.

Fig. 27, the olive crown; this was awarded to him who had signalized himself by feats of gymnasium, in the different arenas. The olive tree was originally a native of Asia, whence it was transplanted into Egypt, and the South of



Europe; the wood is heavy and of an agreeable odour; the fruit is of the form of a damson, with a soft oily pulp, and a hard nut in the centre. The olive was consecrated to Minerva, by the Athenians, who regarded the culture and protection of the olive tree as a religious duty. The oil of the olive is pre-eminent among vegetable oils, and has not only always had an exten-

sive use in culinary purposes, but formed the menstruum, or vehicle, for the most celebrated perfumes.

Fig. 28, was made from the branch of a green oak, and was awarded to the soldier, who had saved the life of a Roman citizen in an engagement, and was considered the most honorable, although of no better materials than the oaken



bough; the reason why this wreath had the preference to all others, because it was sacred to Jupiter, the guardian, of their city; besides this, the oak might well claim the preference in this case, the tree alone being almost sufficient in primitive time to preserve life;—its acorns were their diet, and its honey their liquor. Persons on whom this merit was conferred, when they attended any public show, the senate and the whole of the attendants, would rise on their entrance, to signify their respect, and they were allowed to take their seat among the senators.

Fig. 29 is a triumphal crown, made of the laurel, and was presented by foreign states and provinces, to generals who had gained great victories.



Fig. 30 is a crown of valour, being a circlet of gold, raised with palisades and jewels, and was awarded to him who had first forced the enemies' entrenchment.

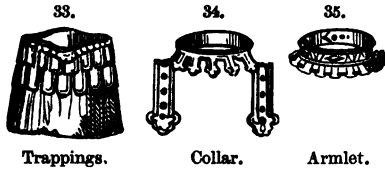

Fig. 31 is the naval crown, bestowed on those who had distinguished themselves at sea; this was set round with figures in the form of beaks of ships.



Fig. 32 is the mural crown, awarded to those who first scaled the walls of any city in a general assault, and under these circumstances, we must suppose why it is formed in the shape of battlements and brick-work.

The most remarkable person upon record in history, for obtaining the greatest number of rewards, was *Dentatus*; he received in the course of his military services, eight crowns of gold; fourteen civic and three mural crowns; eighty-three golden torques, or collars of gold and silver; sixty golden armlets, for the upper part of the arm; eighteen *hasta pura*, or small spears of wood, generally bestowed on him who had killed an enemy engaged hand to hand: these were reckoned honorable gifts. From this it is supposed, the custom of our officers carrying white rods, as ensigns of their places, originated. He also obtained seventy-five *phabræ*, or horse and body trappings, see figs. 33, 34, and 35. But still further, in honour to victorious generals, a number of days were kept as holidays, and the



ceremony of triumph was conducted in this manner: scaffolds were erected in the forum,

and different parts of the city; the spectators were clad in white garments, the temples were strewed with wreaths, garlands, and perfumes. This triumph lasted three days: on the first day was carried the largest statues, pictures, and images drawn upon chariots; on the second day was carried the armour, which was piled up in order; such as helmets, coats of mail, shields, targets, bucklers, quivers of arrows, and horses' bits: through these were intermingled swords and spears. On the third day the trumpeters announced the procession of the oxen, led to be sacrificed, accompanied with the consecrated bowl, and gold and silver cups, of the most elaborate workmanship; then came the chariot, in which was placed the armour, diadem, &c. of him that had been conquered: after this, were carried some hundreds of crowns, sent from the different cities, from their respective ambassadors, as a reward due to their valour. Then came, seated on a chariot, the victor, clad in a garment of purple and gold, holding in his hand a branch of laurel, his army, likewise, bear-

ing the same, and singing songs of triumph. When any general had killed a chief commander, the arms of the slain captain were carried on a stock of oak, before the victor. The first who performed this piece of religion was *Romulus*; and all the spoils were taken and presented, first, to *Jupiter*, and, secondly, to *Mars*, in form of trophies.

Besides all this, they had porticos, temples, and arches. These arches were public buildings, designed for the reward and encouragement of noble enterprises, erected generally to the honor of such eminent persons as had either gained a victory of extraordinary consequence abroad, or had rescued the commonwealth at home from any considerable danger. At first they were plain and rude structures, by no means remarkable for beauty or state; but, in latter times, no expenses were thought too great for rendering them in the highest manner splendid and magnificent: nothing being more usual than to have the greatest actions of the heroes they stood to honor

curiously expressed: or the whole procession of the triumph cut out on the sides. The arches built by *Romulus* were only of brick; that of *Camillus* of plain square stone; but, then, those of *Cæsar*, *Drusus*, *Titus*, *Trajan*, *Gordian*, &c. were entirely marble.

As to their figure, they were at first semi-circular, whence, probably, they took their names. Afterwards they were built four-square, with a spacious arched gate in the middle, and smaller ones on each side. Upon the vaulted part of the middle gate hung little winged images, representing Victory, with crowns in their hands; which, when let down, they put upon the conqueror's head, as he passed under in triumph.

The columns, or pillars, were none of the meanest beauties of the city. They were, at last, converted to the same design as the arches—for the honorable memorial of some noble victory or exploit, as well as to hand down to posterity the chief ornaments of the sepulchres of great men; as when *Juno*

foretold the death of *Sarpedon*, and speaking of carrying him into his own country to be buried, the following words are very attributable:—

“ There shall his brothers and sad friends receive
The breathless corpse, and bear it to the grave ;
A pillar shall be rear'd, a tomb be laid,
The noblest honor earth can give the dead.”

HOMER'S ILLIAD.

The pillars of the Emperors Trajan and Antoninus, have been extremely admired for their beauty and curious work, and therefore deserve a particular description.

The former was set up in the middle of Trajan's Forum, being composed of twenty-four great stones of marble, but so curiously cemented, as to form an entire stone. The height was one hundred and forty-four feet. It has one hundred and eighty-five winding stairs, and has forty openings for the admission of light. The whole pillar is incrustated with marble, on which are expressed all the noble actions of the emperor, but particularly in the Dacian war. One may see all over it



the several figures of forts, bulwarks, bridges, ships, and a great variety of arms, such as shields, helmets, targets, swords, spears, daggers, &c., together with the several offices and employments of the soldiers: some digging trenches, some measuring out places for tents, and others making a triumphal procession. But the noblest ornament of this pillar was the statue of Trajan on the top, of a gigantic size, being no less than twenty feet high. He was represented in a coat of armour proper to the general, holding in his left hand a sceptre, in his right a hollow globe of gold, in which his own ashes were deposited after his death.

The column of Antoninus was raised in imitation of this, which it exceeded only in one respect, that it was one hundred and seventy-six feet high; but the work was much inferior to the former, as being undertaken in the declining age of the empire. The ascent on the inside was by one hundred and six stairs, and the openings in the sides fifty-six.

The sculpture and other ornaments were of the same nature as those of the first; and on the top stood a colossus of the emperor.

Both these columns are still standing at Rome; the former most entire. But Pope Sixtus the First, instead of the two statues of the emperors, set up St. Peter on the column of Trajan, and St. Paul on that of Antoninus.

largest description of arms the most prominent feature for the centre and base. If military, the arms introduced must be according to the era; a cuirass, supported by the largest guns and carriages, shewing the mouth and breech if possible, breaking the symmetry by wreaths of laurel, or subjects of a similar description; then should be introduced the smaller arms, rising gradually from the base, keeping the smallest arms to be thrown carelessly around in a radius position; the whole should be encompassed by banners, but without formality: let these principles be your leading character. For naval trophies, observe the like principle, and, instead of being conical, they should be semicircular, as you cannot find sufficient articles to give a light appearance to your design. Implements of naval warfare to be introduced, should be the stern, or the prow of the vessel, and those the most prominent; with anchors, compass, quadrant, and various other articles connected therewith. Mixed trophies are composed of naval and military

arms of all countries, and all ages. The finest specimen now standing of British arms, ancient and modern, is the one compiled by an Englishman, on the grand staircase in the Tower of London. After perusing these ideas, to furnish your mind for such objects, feast your eyes on all around ; you will then find sufficient to accomplish all you may wish for in that department. I have now given you all the information I consider necessary for your basis ; and, to perfect yourself, study the artist* who honoured this country by his indefatigable perseverance and attention in accomplishing a display of arms, in a manner rightly termed a master-piece, and for which he was justly awarded a pension of two hundred pounds per annum ; and I may with justice quote,—

“ He was a man, take him for all in all,
We ne'er shall look upon his like again.”

He was not famed for deeds of arms, but only for the display of them ; and it proves, by

* These were arranged by a man of the name of Harrison, a carpenter, employed in the Tower, in the reign of William and Mary, and, by their orders, he planned the several designs and stands of arms as they now appear.

perseverance and industry in obtaining a taste for design, how many forms may be made, and changed about, by having only one description of article enumerated.

Who would imagine that the figure of the seven-headed hydra could be formed from pistols and daggers, or St. George and the dragon from sword-blades? I would advise my readers to see, and judge for themselves; but I will illustrate a few of the leading points, and various arms in ancient and modern use.

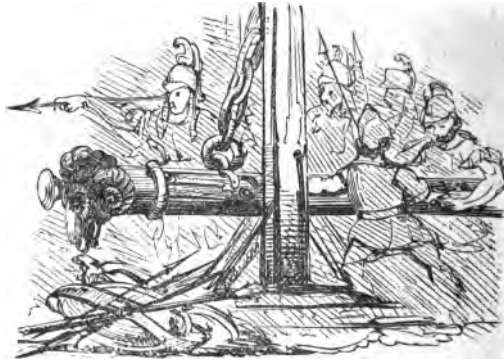



like and murderous weapons, to defend, or offend. The earliest of these were, no doubt, of wood or bone; and as the arts increased, and metals were discovered, these instruments attracted great attention for their utility. To speak of copper swords may seem very strange to many; but that metal was wrought long before iron, and applied to domestic and general purposes. We find in Homer that all weapons were made of brass; and, from the earliest time, they were highly enriched. Some of these weapons have been assayed, and found to contain a portion of iron and zinc; and are supposed to have been cast, and filed, to give the necessary rigidity of a weapon. It should be observed, that the swords of civilized nations were straight, and those of barbarians curved.

As this forms but a small part of the information necessary in this work, I shall return to that portion most suitable for building and ornamental purposes.

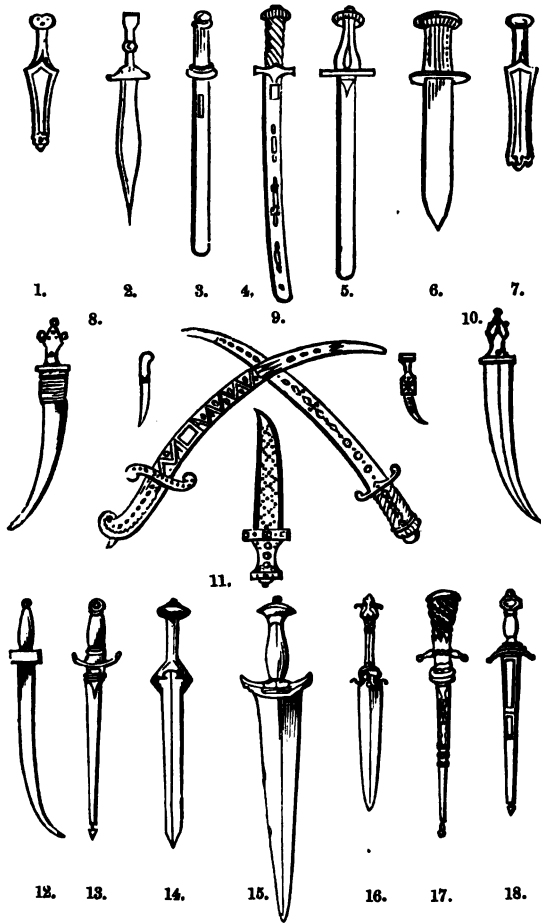

1, 3, 4, 5, 6, 7, ancient Persian swords and daggers; 2, 14, 15, 16, Roman swords; 13, 18, Grecian swords; 12, Dacian swords; 17, ancient swords of the Jews; 9, Turkish sabres; and 8, 10, 11, Turkish daggers.



It is not my intention to enter into the history of Egypt; but, as before stated, simply to give you the necessary information and correct figures, should you at any time require them. It is imagined by a great many, that any *twisted line* will form either Egyptian,

Chinese, or Arabic characters, or any *grotesque figure* will form either an *idol* or a *god*; but the days of improvement and literature are so far advanced, that it behoves every one to be careful how he speaks, and still more careful how he acts; and although Egyptian architecture is not based on such rigid principles as others, in conformity of a number of members, as other orders of architecture, yet many state that two oblique lines, a hollow, a fillet, and a reed, are almost sufficient to erect an Egyptian temple. But all this requires proportion, to give it the grandeur it possesses. The first form is the great hollow, which their cornices were made to assume; these were sometimes ornamented with a perpendicular reed; and this, in character with its primitive members, few and bold, appropriately simplified to the earliest works of art. By mental culture they sought for beauty in the sublimity of nature; and, from their limited architectural skill, sought those objects that would excite the feelings, or gratify the mind; and hence

it was that the subjects of nature, and particularly those of the vegetable world, were soon reduced to the purposes of decorative taste. I have read many authors, who assert, they commenced decorating the tops of their columns, that it should be secure from the reach of injury; but this I deny, as the base and shaft of the column were alike decorated. The chapters of their columns were confined chiefly to the palm tree and lotus leaf, but laid out in various forms.

Variety in beauty is next to be sought after symmetry. It is commonly imagined that it requires a number of different articles to produce variety; or, that a number of different qualities must exist in the same thing,—thus compounding diversity with variety. An almost endless variety may be produced, by altering the position of any one single object. The contrast in the position of objects of the same kind, is the fundamental principle of variety. On this basis were the columns of the Egyptians founded. The idea of an analogy

between the top of a column, and the blossoming summit of a tree, furthered their principles



for beauty, which made them form the shafts of their columns of reeds and scales of the palm-tree bandaged together, and seemed as if springing from a bed of flowers

or leaves, for an ornamental base.

Thus far, I think, you will admit, sufficient has been treated to you on this early style of architecture, of which the following figures will exemplify; and I shall now commence with their decorations, relief, and sculpture, principally derived from nature.

It is more reasonable to suppose that the palm tree was originally used for ornamenting their chapiters, as many of them are formed of the scaly portion around the shaft, and the branches springing to form the capital; but, in fact, we may trace the imitation of natural objects in every portion of an Egyptian column. Square

and octagon columns have also been formed ; and figures were introduced, as caryatid, but chiefly



Caryatid Pilaster.

used as pilasters. The most common form of a capital was that of the calyx of a plant, chiefly the lotus ; which simple plant received the most graceful modifications from the Egyptian mason, for the purpose of architectural ornament ; even the bulrush has been introduced. One of the most curious capitals is that of the portico of Danderah ; it is of a quadrangular form, with the head of Isis at each facing ; and above that,

the model of a temple, previous to reaching the architrave, or cornice, which has a very imposing effect, and seems to have been intro-

duced on many other monuments, intermixed with different portions of sculpture.

The only specimen that I can refer to as regards the idea of an Egyptian edifice, is the Egyptian Hall in Piccadilly, which was erected at sufficient expense to have enabled the builder to have represented an exact model of an Egyptian temple; but some portions, however, of the upper stories, are sufficient to give to many the character of its style: a few half round mouldings up the side, and a bold carved cornice at the top, finishes this Piccadilly temple. There is a very striking difference between the Egyptian and Grecian decoration: the geometrical figures of Egyptian columns render them more deserving of merit than the Roman or Grecian, as they had only one foundation as regards its figure; whereas, had the Egyptians finished their leaves as the Greeks have done, in many instances they would have commanded greater power on the mind for grandeur of design, than the after ages of Grecian and Roman beauty; but, as it is, we

cannot familiarise ourselves with an Egyptian portico, as it has an incomplete appearance.

The genuine rule for Egyptian pillars is of irregular rounded forms, but of no established diameters; but when the eye is accustomed to look on the Ionic or Corinthian column, the Egyptian then appears stunted; as they seldom took above five diameters, and the Composite and Corinthian, nine: the bottoms were like the leaves of the lotus, rising above a number of concentric rings, binding the columns like the hoops of a cask; and above them are vertical cuttings, giving the

38.

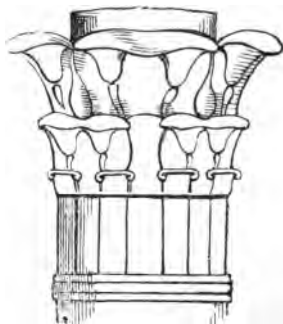

Lotus.

appearance of a bundle of rods which, I have no doubt, gave rise to the flutings of columns,

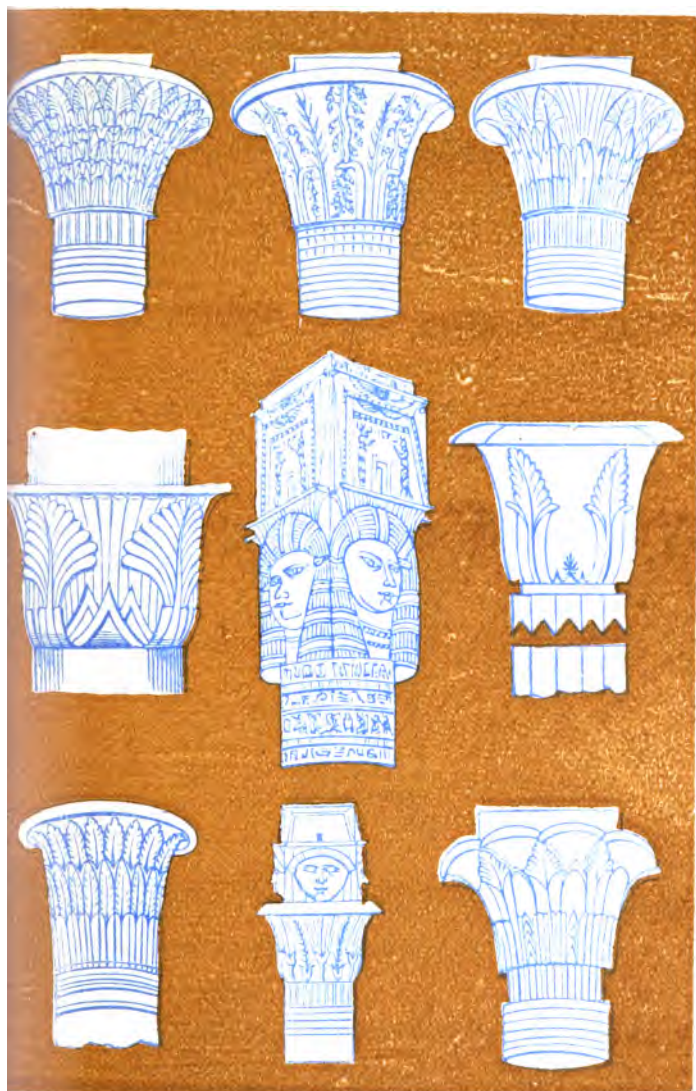

only other orders are always concave, and the Egyptian convex. Some have been erected to the height of forty feet, including their capitals, and about twenty-eight feet in circumference.

Another style of pillar is, apparently, nothing more than a number of palm trees bound together, to make a strong support. I have read, from the works of a French traveller,

39.

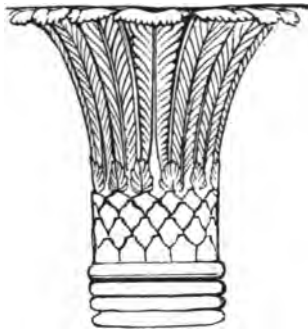

Palm.

who asserts, that the origin of these massive props was from the slender stalks of the lotus.

The forms of animals having been delineated on the different sculptured monuments with

such scrupulous fidelity to nature, that we cannot help inquiring into their origin; and, further, when we find these animals not only sculptured, but embalmed and entombed, is a just cause why we should do so. Ancient writers have transmitted to us that it was a religious system; and we have had before us a spacious field of research, which has been dregged by the most zealous inquirers and travellers, but is still found to be a difficult task to authorize, for certainty, the real cause for such objects. Innumerable conjectures of ancient and modern writers are that we should place this with the Hindoo superstition. As we are as far off as ever from having a satisfactory conception of the origin, or symbolical meaning of the greatest portion of Egyptian forms, my object on this will be limited, in regard as remarks on their religious systems, but merely, compare the sculptured figures on existing monuments in the British Museum, with the forms of animals now extant.

It is not from personal experience that the

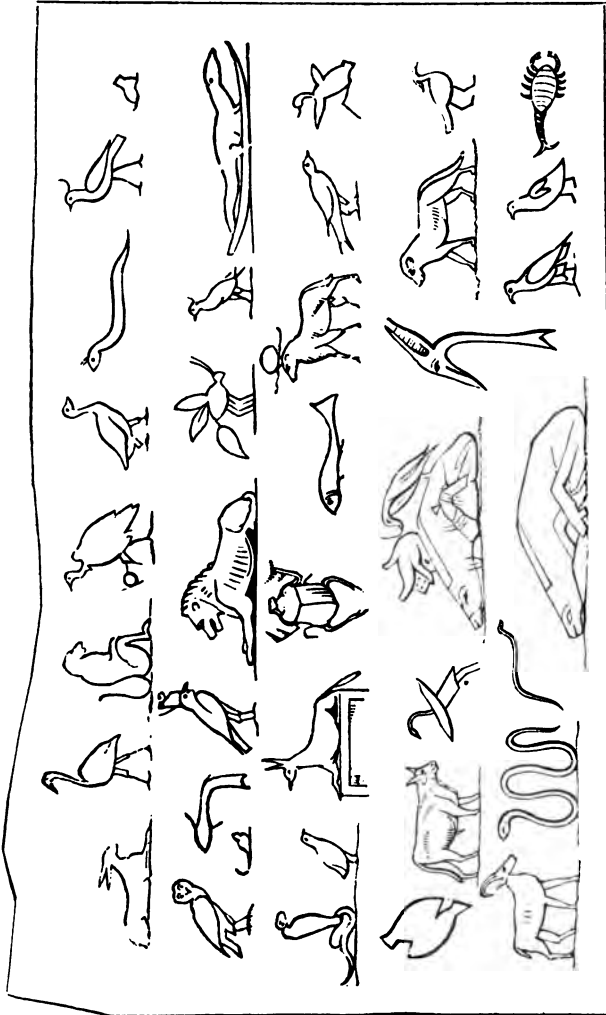

following remarks are laid before you, but from the most authentic writers of the past and present day upon that subject alone.

The print herein given I believe to contain the chief, or nearly the whole variety of animal forms, birds, &c., then introduced.

The bull was one of the sacred animals of Egypt, and formed a model for the god Apis, or great visible deity of Memphis. It has been observed on fresco paintings, with a hump on his back, like unto the Bramin bull, (as may be seen at the present day at the Zoological Gardens,) whose appearance, I consider, denotes kindness, gentleness, and beauty of form not seen in any other animal of its kind; but they were never embalmed. The antiquity of worshipping the bull, is shewn by the fact of the Israelites falling into the gross idolatry of worshipping the golden calf. I am not quite sure whether all sacred animals were embalmed, or were used as hieroglyphics, or both; but I should suppose they only embalmed those animals that they held sacred—the cow, the bull,

the horse, the camel, and the giraffe;—the ostrich, and others, were chiefly thrown into the Nile. The dog, the ram, the she-goat, the fox or jackal, the monkey, the hawk, the ibis, the crocodile, the lizard the goose, the owl, the crane, and the scarabæus, or beetle, have been found embalmed. The serpent, scorpion, lion, fishes, and many others seen in the foregoing plate, were used as hieroglyphics, as well as for worship, among the rest.

This trifling information, as I have previously said, is not for history, but utility: as, in describing Egyptian architecture, any of the above named figures may be introduced with propriety, and the introduction left entirely to the taste of the artist. In many reasonable works on the history and customs of the Egyptians, will be found detailed accounts, and forms and characters of their writing, which I could of course give; but previously to entering upon that description of study, I should advise you to obtain them, that your ideas may be carried out with accuracy.



I will now return to the variety of their columns, cornices and chapiters, chiefly composed of the palm, the reed, and the lotus, of which the annexed plate is a specimen. This is compatible in appearance with the Roman and Grecian; here you see a grandeur and weight in the composition of the lotus, with a neat and graceful appearance of the palm. After being well acquainted with their irregular principles, it is very little use attempting to design upon them; you may, of course, arrive to a certain degree of perfection, but still there is an appearance, in my opinion, as well as others, about the originals, which gives a pleasing effect. The Egyptians based their ideas upon nature's form, although in a rude style of drawing, but yet above all conception of after-ages in grand productions, as regards massiveness of sculpture; and it seems, that when they found an immense vein of rocky substance running in the earth, they were not contented till they formed immense temples, or sepulchres, hewn out by manual labour from the

solid rock, leaving intervening masses, of which they formed their columns, and sculptured hieroglyphic ornaments upon them, which are handed down to the present day.

It is unnecessary to dwell longer on this; I shall leave the remainder to illustrations, and now treat upon a very opposite style, and which character is greatly in use at the present time, but seldom accomplished accurately, namely, Louis the Fourteenth's



Lotus Boss.

ON FRENCH ORNAMENT.

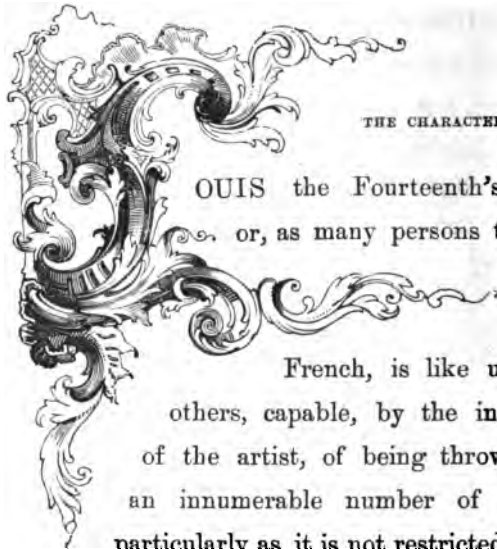

THE CHARACTER OF

FRANCIS the Fourteenth's style,
or, as many persons term it,

French, is like unto all others, capable, by the ingenuity of the artist, of being thrown into an innumerable number of figures particularly as it is not restricted to any decided form. You have the liberty in this description of decoration, of using even the square octagon, or any other geometrical outline you may feel inclined to base your design upon; its

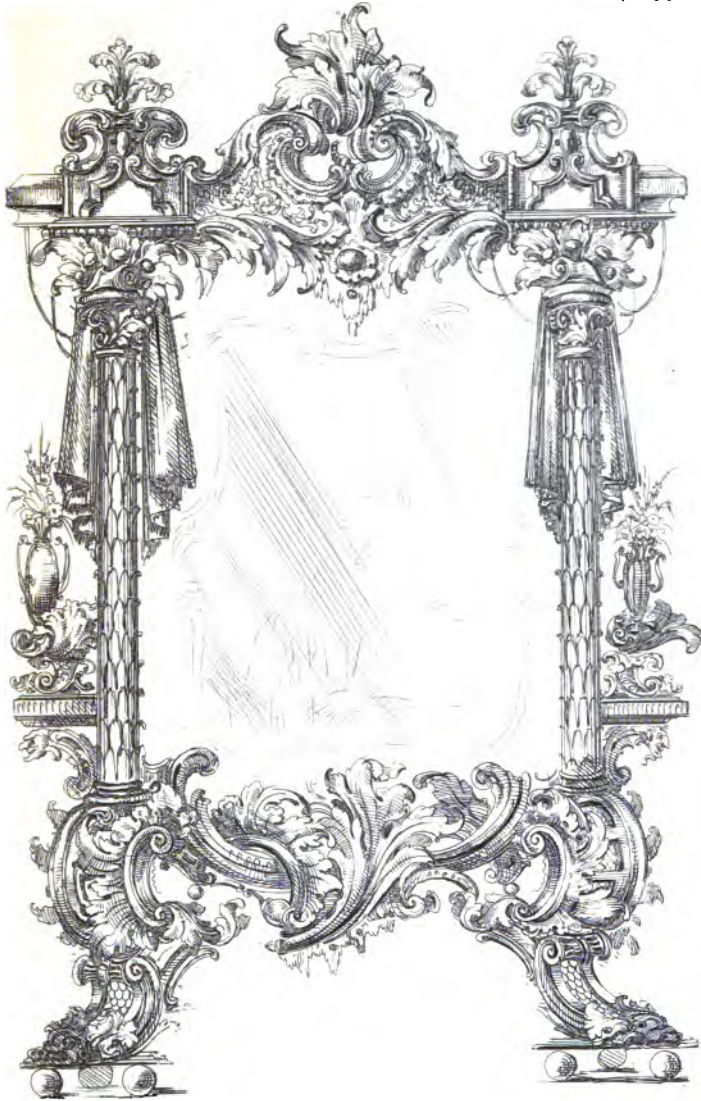

J. Page, Del et Sc

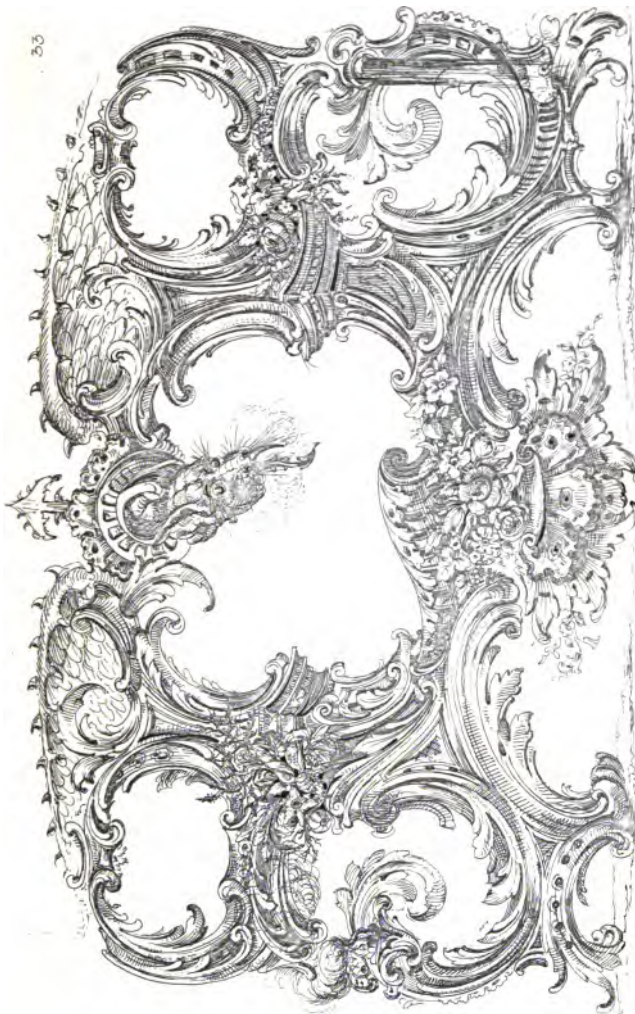

FRENCH

J. Page Del. et Sc.



del. sc. et sc.

principles being quite reverse to all other characters, and, for that reason, I intend dissecting almost every portion of the French, or Louis the Fourteenth's style, which meet at angles, either right, obtuse, acute, or that which partakes of the mixed curve; when I say obtuse, acute and mixed curve, I mean as the four annexed

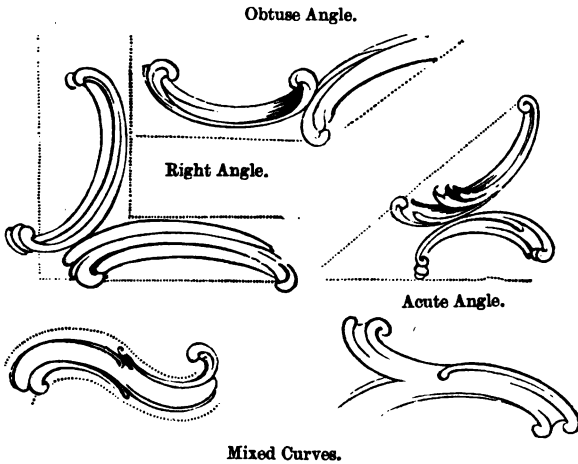

figures shew, that by lines of this kind, you may by attention, very soon plan a design for anything you may wish to introduce in this description of ornament. Having sufficiently studied thus far, your attention should next be

drawn to the disposing of these different forms, so as to place them agreeable to the observer ; the principle of which I will now lay before you, by such rules as I have always found to possess the most pleasing forms. In the annexed plate you will perceive a number of plans introduced their basis being shewn by a heavy line ; and around, you see upon what principle you should roughly sketch in the adjoining parts to complete the design, after throwing carelessly around such pieces as you, in your imagination, may think suitable for the purpose. Having gained this position, rub out the careless outline, and commence placing such portions as will appertain to the first sketch, being careful to keep the standard form in one continued figure, so that the mere contour will be completed by the introduction of flowers, fruit, animals, birds, figures, or landscapes, which should be introduced in the back-ground : you must be careful what form will surround it, as every thing depends on that. Remember you have two subjects to study, viz.—ornament,

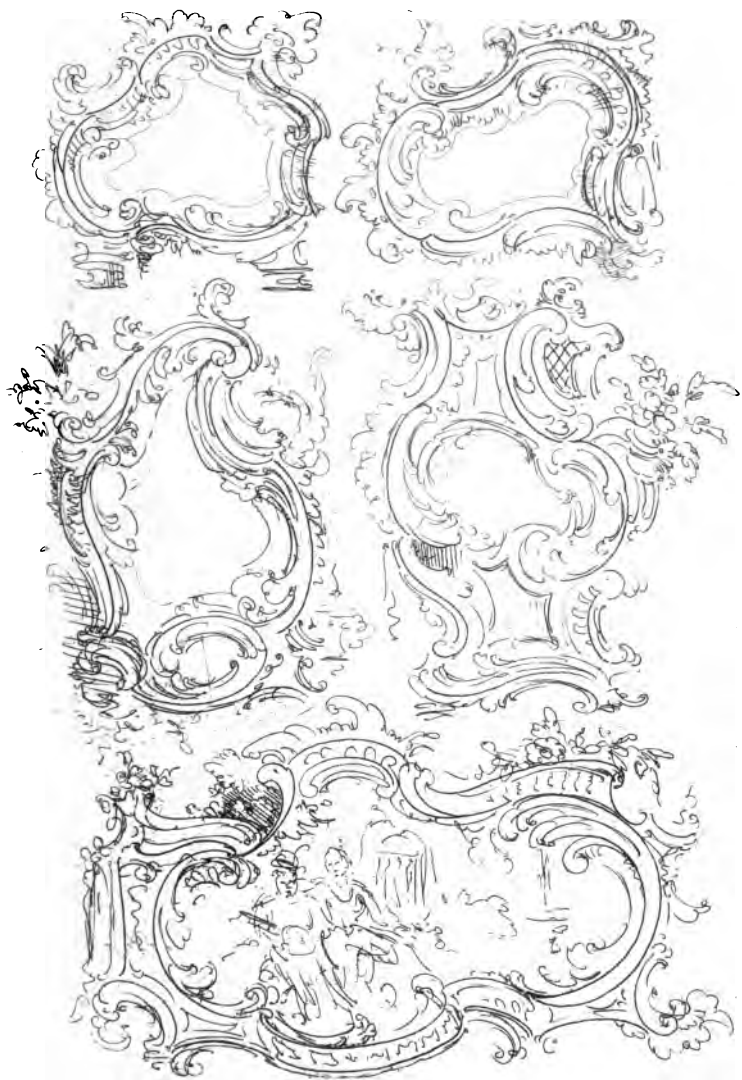



LOUIS 14 BRACKETS

J.P.

which should be prominent, and landscape, which must retire in the distance, to give a pretty finish to the back-ground, and drawn at such a distance as not to attract attention from the framing. As these two points will require your particular notice, I will give in plate 42, two comparative designs, that may hereafter lead you the right way, and shall here illustrate what forms should be given for the introduction of landscapes, &c. In placing animals amongst your frame-work, never let them stand quite prominent, but be intermixed with scrolls or flowers, that the eye may not retain the drawing of one, and forget the gracefulness of the other. Never introduce animals, or any subject of natural history, unless as incidents, without rendering them interesting, and, if possible, graceful. Incidents of this description should be managed in the following manner:—where two curved or angled scrolls meet, as shewn in these diagrams, there is room for subjects of the following description: such as a dog alarmed at the appearance of a serpent, a tiger at an

hedgehog, or a bird at a dog; a small portion of water, with a swan in graceful position,



pecking at a snake; a dragon and lizard in combat; dragon and eagle; rabbit and cupid; cupid and vines; in fact, the greater the contrast which may occur in your imagination, oftentimes the better the design; but, as before stated, always have something interesting in view, but let these be placed in the most graceful postures, and in the most convenient places, so as not to disturb the whole outline of the design from the attention of the observer.

Figures, when properly managed, have a very amusing appearance; but, to be prominent, they should be sparingly introduced, unless the article manufactured, chased, or drawn, is for some particular purpose; or, when otherwise, choose such subjects, as are either historical or fabulous, ancient or modern; and

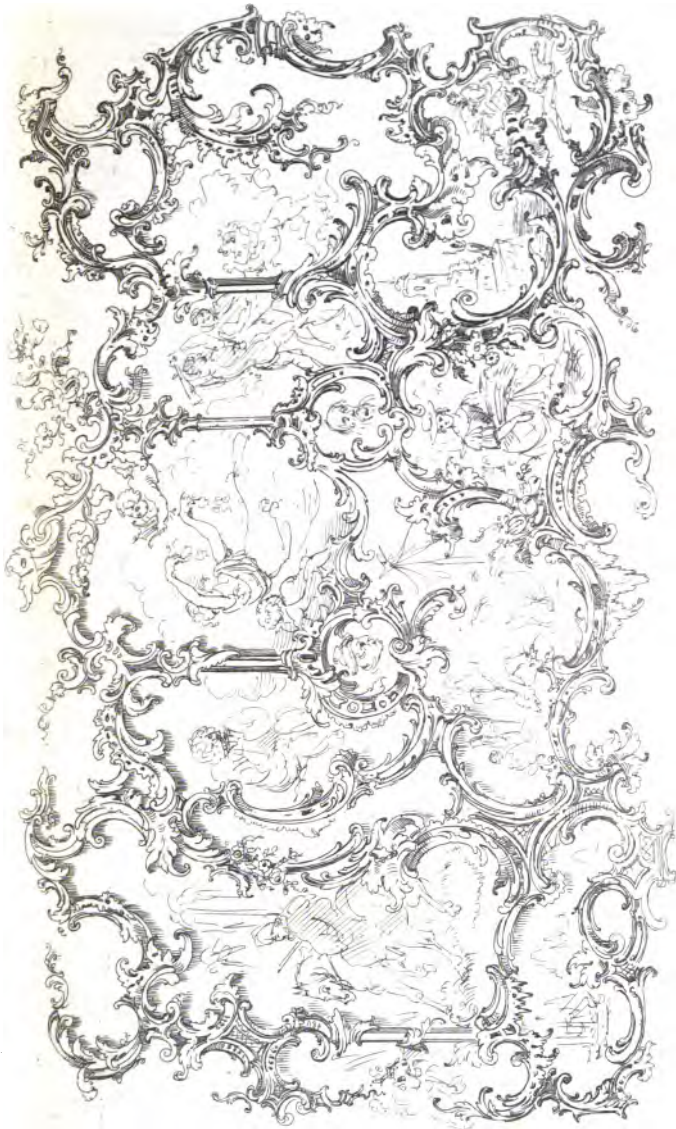

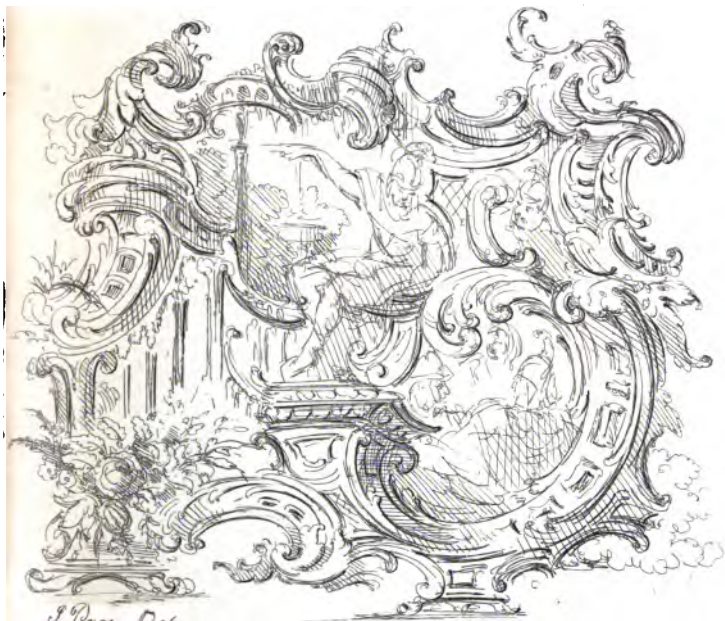

J. Page, Del.



always study to group those subjects that are most likely to attract the attention of the general observer, and which are most generally known. Mythological figures may be very often introduced with propriety and effect,—as the different parts of the scroll-work present opportunities for displaying the various sudden changes, which are generally understood to have taken place with the heathen gods and goddesses; and the minutæ around, should be those emblems that may lead to the discovery of the artist's imagination; but do not let these objects, so combined, be confused, for that would ruin the whole, however good the drawing or the idea. I have alluded to this point before, but in this description of ornament it is of greater consequence than in any other; although there is a vast difference between Louis the Fourteenth's and what is generally termed the French; as the first-named is often composed of a very massive and rich description, which is perceived in the designs of *Le Potre* and *De la Bella*,

whose principles of design I intend illustrating from their chief works, as well as many others ; and, by those means, perhaps, cultivate such taste, as may hereafter be beneficial to the workman and the student, as all these studies and styles are to be divided into several compartments, previous to their forming a complete subject.

I shall now commence anatomizing that ornament which is termed Louis the Fourteenth's, and, if possible, prove, by your exertions and my instruction, that there still exists a beauty and richness in this description of ornament, that will always be a standing dish of paste ; although *Mr. Hope, a dear friend to the style,* in his *History of Architecture*, observes, the want of good taste is seen daily in the mansions and buildings of our great men,—their decorations consisting chiefly of shields and scrolls, of that uncertain and irregular style used in Italy, and, soon after the re-adoption of the classic style, passed into France ; which, about the time of Louis the Fourteenth, be-



came so neutralized, as to be termed the style of his period ; and, within a few years, through an inordinate desire for novelty, this frippery style became quite prevalent in England, and all the old clumsy scroll, which the French had long rejected as unworthy, has been eagerly brought to decorate the houses and mansions of the present day ; and not content with ransacking every pawnbroker's shop in London and Paris for old buhl, old porcelain, old plate, old tapestry, and old frames, they even set every manufacturer to work to corrupt the modern taste, by the renovation of this wretched style. *However wretched*, still the cork must go with the stream ;—and so it is with the employer and the employed ;—whichever way the employer opens the flood, the taste or plans of the artist seldom stop the rush, however dirty the waters may be, but he must float with the stream himself immediately, and get out of it not only with credit to himself, but try to obtain the admiration of all observers ; and that perhaps, you may do, through a little assist-

ance, and I sincerely wish you success. To aid it, I will lend you a preserver, although

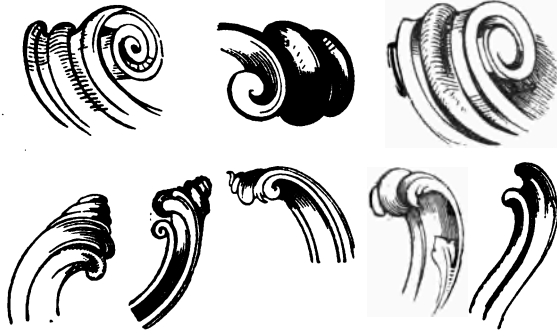

Block Volute Heads.

in pieces, which I have no doubt, you will be able to arrange together for your own safety.



Shell Heads.

This kind of ornament is divided into a number of portions, as block volute heads,

shell and foliated heads, as seen in the annexed, figures; these are the points that terminate at various angles, as the arch, either ribbed, plain, foliated, shelled, or perforated; centres composed of shells, foliage, or figures, either for the top or bottom of the design; the lattice, plain or scrolled; the fish-scale panelling, for different descriptions of tables and brackets; tapestry droppings; shield, both scrolled and



Scroll Heads.

shelled; the balustrade, flowers, and fruit. In arranging all these compartments, it is necessary to inform you, that it is not compatible with good judgment to introduce the whole of them at once; by so doing, you will very soon exhaust your store. But suppose for instance, you make a design of a number of ribbed

arched friezes,—at one angle, you would put a shell or scroll head, at the other side, a table or bracket; to these different portions you might add the shelled arches, as the following figures; in another portion, the scrolled arch, and these parts broken by flowers or fruit, with square tablets and panelling. Be sure not to place these pieces together, but sepa-



Scroll Shell Centre.



rate them as much as you can with convenience, so as to cause a variegated appearance, as I



Scroll Shell Centre.

mentioned before, that by proper management a great variety may be made by one single

object, and I do not know where a better op-



Scroll Shell Centre.

portunity is given than in this instance. I shall now arrange the different arch pieces.

Fig. 40 is termed the ribbed; fig. 41 the perforated; fig. 42 the shelled; fig. 43, the flowered; to which you may add fruit, or any other object that may be pleasing, as shells, small openings for paintings, or water-falls, and heads of figures, or dolphins. Having shewn you the various arched pieces, centres, and



finishings, which combined, are the rudiments of this description of ornament, I will now

refer to that portion called panels and tablets, which are faced, or otherwise fitted with lattice-work, fish-scales, and eccentric curves; these may be either perforated or solid, which depend entirely on the article manufactured, whether it be of metal or wood; for, when it is perforated, it has, in most instances, a meagre appearance, and defeats the solid and rich appearance of this description of decoration.



Panellings.

Tablets and panels are mostly placed between the finishings and angular joints of various combined arched friezes, and are often moulded, instead of the aforesaid mentioned fittings; but this must be done only where there is a small compass to fill up, as it then will give the appearance of a solid and firm piece of frame-work. I will now draw your

attention to a practice, which I have often seen represented *both right and wrong*, viz., the placing of tablets or panels at two opposite



a, b Panellings.

angles, or many on one side, and none on the other; for instance, in the two previous diagrams, you see the effect they produce; and, on your referring to the various plates, you will

see, by management, and avoiding any definite outline, they have a very pleasing appearance; but all this depends on study, and furnishing your mind with every finished termination, and this is done only through practice and perseverance; but most draftsmen, after knowing a few component parts of various ornaments, when feeling themselves at a loss, and in want of something to fill up a vacancy, and not knowing the different variations that this simple ornament may be changed into, have immediate recourse to panelling; never studying or thinking of the observations that may be passed by others, who, perhaps, do not possess their talents, but have persevered so far as to understand the different compartments, and yet not sufficient ideas to be able to form and complete a design. To enable those who have not talent in arrangement, sufficient to compete with their perseverance in study, I would advise them to notice the general variety of diagrams heretofore given, and by drawing and cutting out a number of these pieces, of various

sizes, they will be enabled to join and plan many designs and forms, which might not otherwise have occurred to them, even after an immense deal of study; it is a very simple plan, and I think will prove advantageous, and repay the labour it may at first cost. The idea is not a new one, except to this purpose, as many would, and perhaps will say,—any one could have done or found that out, because it is so simple;—but, like *Columbus and the egg*, if they had thought of it;—this is not intended to damp your imaginations, but having proved the same, I consider it my duty to inform my friends of it, and they, of course, can use their discretion in putting it into practice.

I will now refer to the department of tables and brackets, which comprise another very prominent feature in this description of decoration, and partake chiefly of acute and curved angles; their chief feature is prominent mouldings, scroll-head finishings, angles, and the bases finished with scroll leaves, shells, and flowers, as the following figures shew; their utility is

to finish off prominent points, where any necessary articles, or symbolical ideas, may be required; and its beauty consists in blending the same with the accompanying scroll, or frame-work, in an imperceptible manner, with freedom, to the body of the design. In some instances, this ornament, in Louis the Fourteenth's, is of a firm and decided form; but in Louis the Fifteenth's it has always seemed to me, that they are attached to that meagre and undecided form, termed the Chinese, which, like themselves, are composed of such grotesque forms and figures, never to be understood, although patronised by many whose ideas and mental capacities ought to enable them to form a better taste; but, as its character bestows richness of effect, by various burnishings, gildings, &c., nature, of course, is forgotten. Many, however, assert that they follow nature:—yes, like *Hogarth's perspective*,—the very reverse to what it should be; but as there are at present so many diligent enquiries from some of my friends respecting this description

LOUIS, 14

26



LOUIS, 14



J. Page Del et Sc

CHINESE



GRECIAN

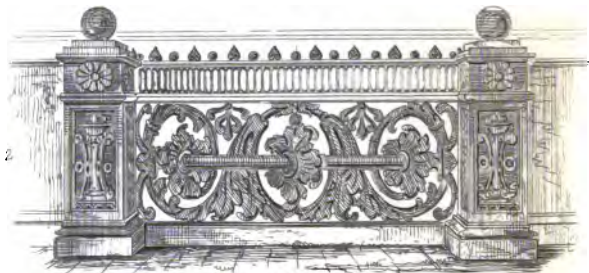

ROMAN

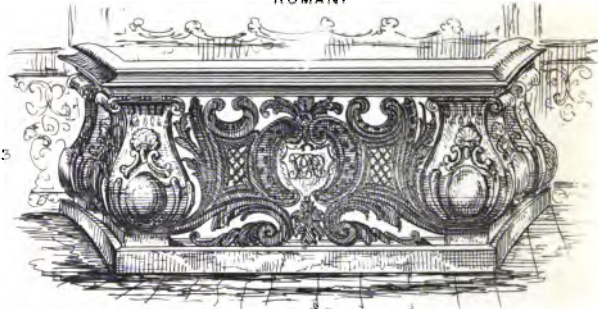

II page, Del et Sc

FRENCH

of design, of course I am in duty bound to do my utmost to oblige them, in explaining and dissecting the same; and shall, after a little more explanation, respecting the French ornament, attack this splendid foreign character, as regards the style of decorations.

I am now departing from my track, and will return to that section, termed the balustrade; as a portion of that, when properly placed, is very acceptable, and breaks, most considerably,



Bracket.

the monotony that would often exist. They are of various angles, and generally placed at the top or bottom of drawings. The following diagram will give you an idea of the shape generally to be used, but be cautious,

and not make too free use of them when you are designing, as they must be used very carefully, for they have a powerful and prominent effect ; but, used judiciously, add greatly to the appearance, as well as the variety of form. The moulded scroll, with block finishing, is the best, and is sure to fall into that outline which will ensure a decided graceful



Bracket.

figure. I would have you pay attention to that part of the finishing in which flowers are a portion ; for, unless great freedom is used, however good your formation and foliage may be, yet a stiffness and want of freedom on that particular point will entirely destroy the other. Now, to avoid this, as in fruit the



FRENCH

I. Page Dei et Sc.

GRECIAN...



J. Page Del. et Sc.

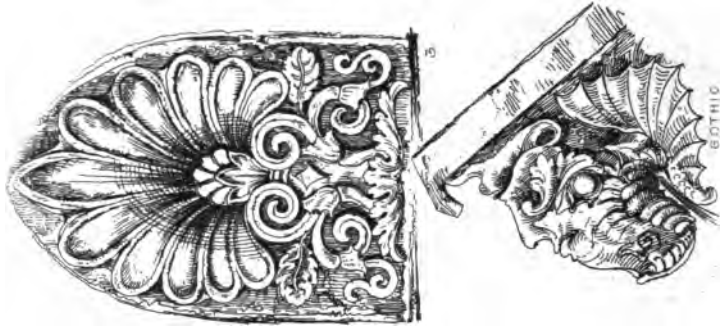

BOTHIC

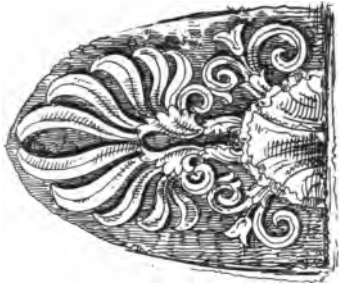

1, 2, 3 GRECIAN STELLA'S



GRECIAN

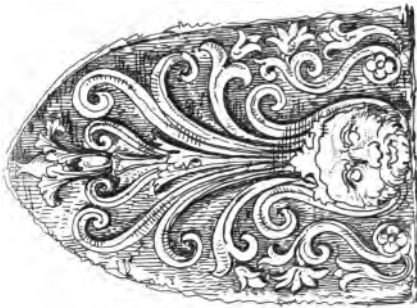

4, P SIDE VIEW

same, you must be very careful, and not crowd too many large flowers together, so as to appear square or formal; but let your flowers be open and straggling, and they will give as great a variety as can be well defined,—I mean those that are generally known.

I will here illustrate a few of the flowers, though it entirely depends upon your own taste, and is a circumstance not biassed or confined to any particular portion or kind; but be careful not to introduce them too profusely.



Balustrades.

In fact, this description of decoration is greatly aided in appearance by the introduction of these articles,—as flowers, fruit, and other items of the kind, and is never finished without them; and for this reason, would have you turn your attention to study flowers from nature, being the best master I can refer you to;

and not only learn to draw them in one position, but turn them in every direction, and copy them, so as to be able, with one flower alone, to form or give the appearance of a group, or variety, when, in fact, there is but one. The same principle must be followed up rigidly in regard to different leaves, their different external forms, and turns,—the vine, fig, dahlia,



woodbine, honeysuckle, convolvulus, rose, and passion-flower leaves, are the most useful, as they have a full and decided character in themselves.

Having now illustrated the most convenient and pleasing sections, I hope it will not be without rendering you an essential service, not only in this, but in all the foregoing diagrams, feeling confident that this system has proved successful to all those who have thought proper to follow my advice; and shall now leave you to your studies, and proceed with that description called Arabesque.

ON FRETS AND GUILLOCHIS.

PREVIOUS to entering into a description of Arabesque foliage, &c., I shall give a number of illustrations of the above-mentioned ornament, the characters of which are purely Grecian, on the part of the *fret*, but may be termed Gothic, on the part of the *guillochi*. The beauty and principle of the *fret* lies in an equality of ground and fillets, meeting at various right angles. To gain this end, it cannot possibly be done by hand, without first laying down a geometrical rule for the same, as with the mixed fret; or that which is partly angular, and partly circular. To accomplish this intermixture of lines or fillets, you must take the width required, and divide it into a certain number of divisions, agreeing with the space allotted, avoiding, if you have a narrow compass, not to put too confused a pattern; and



3

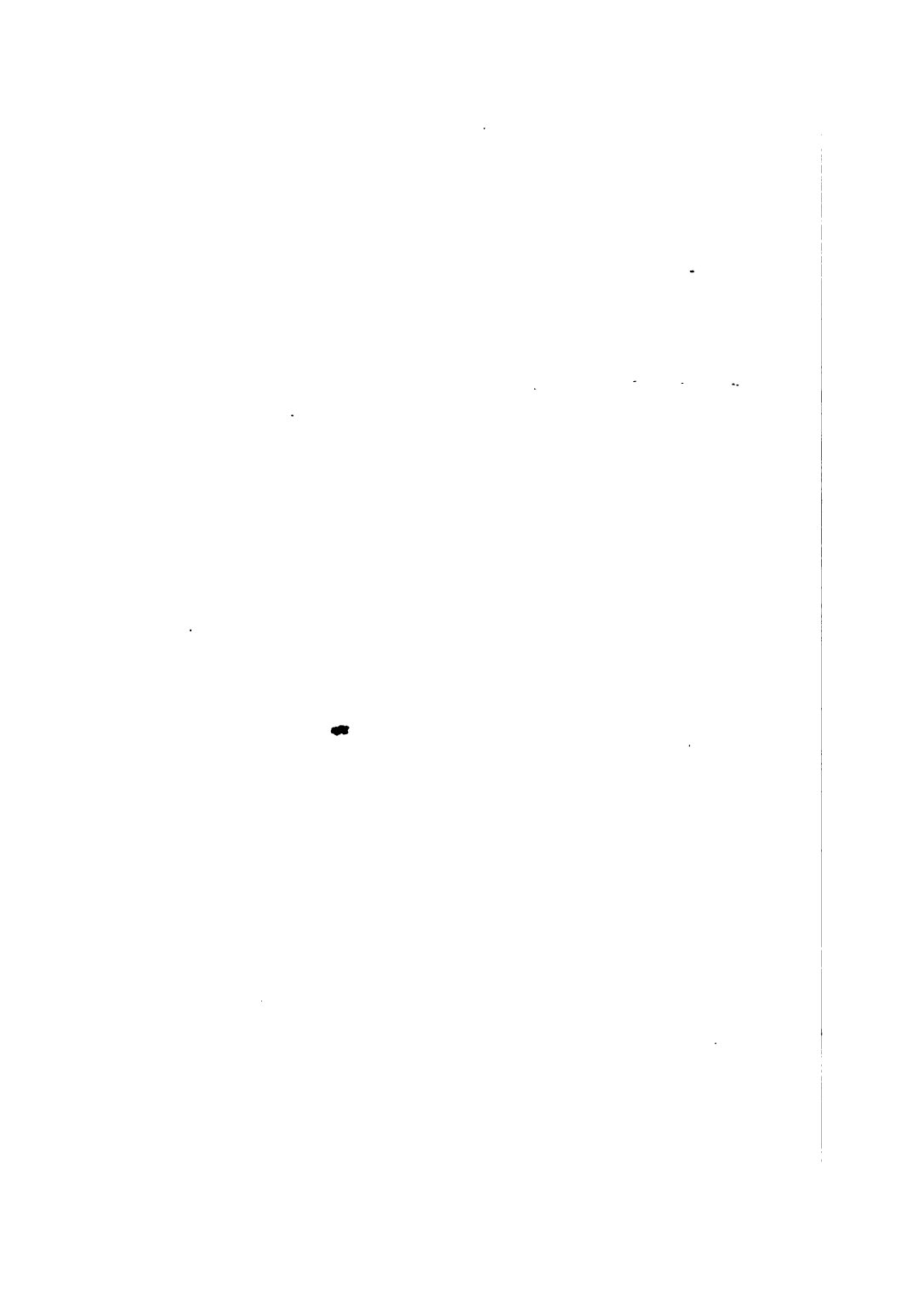

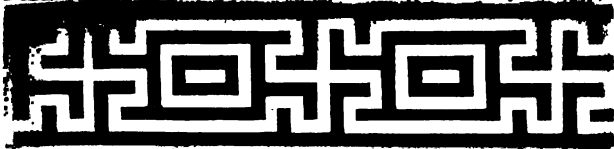

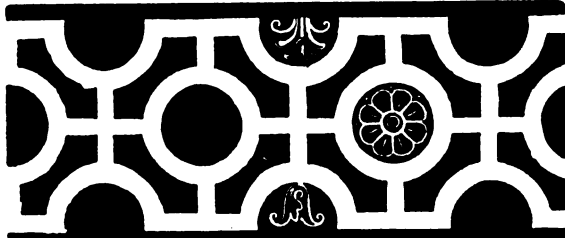
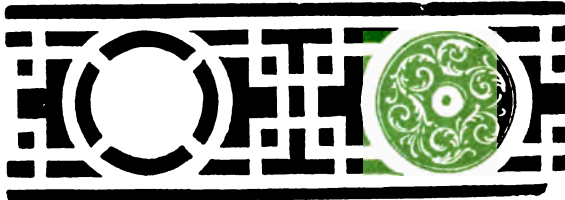
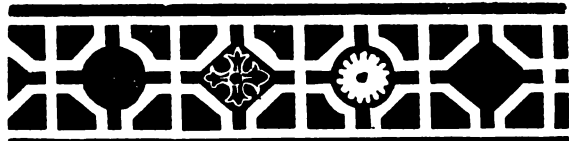

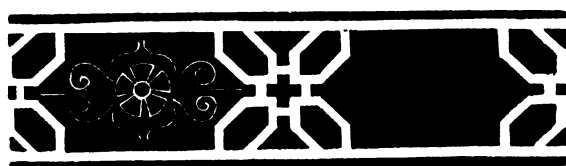
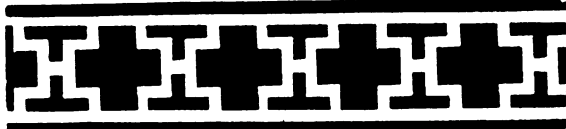
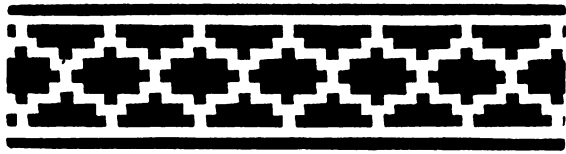

divide accordingly, as the annexed diagrams will shew. The white lines are the divisions;

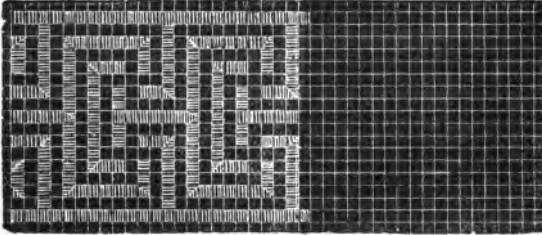

Odd, producing eight fillet fret.

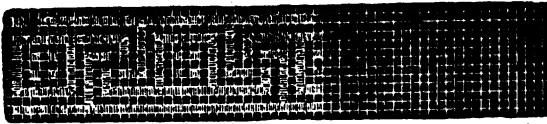

Odd, producing five fillet fret.

and, by making out every alternate one, you gain your pattern. I have given almost every one in general use; but by perseverance, or, as in many instances, by chance, the patterns are unlimited.

I shall next proceed with the *mixed fret*, which is upon the same principle, keeping the curvilinear portion exactly within the division marked out for the angles; and the same may be done with this as with the former ones.

The *guillochis* are on a very different plan, and are formed on different principles; to which may be added a variety of ornamental designs, bosses, or cups. As all these characters rest entirely upon the taste of the designer, or draftsman, I shall not enter very minutely upon this portion of decoration, as it is not so extensively used as many others; but I will shew, by illustration, the rules to be observed to gain many points, which is the chief thing required, and can only be accomplished by geometrical rules.

The following diagram, I think, will be a sufficient guide to all the rest:—

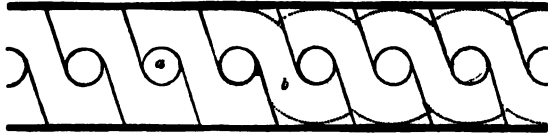

The above simple *guillochi* would, if you knew no principle to work upon, give some trouble to draw correctly. It will shew you the plan I discovered; and I think you will

agree with me, that it is very simple,—but to the purpose. You draw or strike the circles, *a*, at equal distances, and proportionate to the two outer edges; after which, draw your oblique lines, as at *b*; then, by rounding each angle, you will gain the point required.

The other diagrams are upon the same principle, and give you every facility, by study, to draw the following designs, in which I think, every pattern worth notice is given. This description of ornament is useful only to a certain extent, as on a cornice, rim, or small border, as there is not sufficient in itself to be a very prominent feature in decoration; but yet I would have you direct your attention to it, for, in some instances, it is very useful, with judicious treatment, when combined with other ornament.



ON ARABESQUE.

ON referring to that description of compositions, called Arabesque,—of course, I adopt the term as it is generally understood, but must certainly say it has a tendency to the cinque-cento style,—its application being originally confined to the paintings and stuccoes of antiquity, which represent foliage, fruits, beasts of every species, and imaginary creatures, intermingled. This decoration is sometimes called grotesque, from the grottoes or under-ground buildings in which they have been found—the most splendid specimens having been excavated from Herculaneum and Pompeii.

Pliny mentions, that, in his time, gaudy colouring and curious forms were held in greater estimation than real beauties of art. If we examine the ancient Arabesques, we shall find

endless beauty, variety, and originality; graceful details, and great skill and freedom in the mode of execution;—and I doubt whether the Arabesque style really had the effect of discouraging painting of a higher class; as, at Pompeii, poetical compositions of great merit have been found intermixed with this light and playful decoration. Vitruvius describes it rather accurately. After pointing out and classifying what he considers legitimate objects for painting walls, as architectural compositions, landscapes, gardens, and sea pieces—the figures of the gods, and subjects drawn from heathen mythology, he proceeds thus:—“The Greeks, who took truth for the model of their paintings, are no longer followed. Nothing is now represented upon walls but monsters, instead of true and natural objects. In lieu of columns we have slender reeds, of flimsy stems, and leaves twisted into volutes. Temples are supported on a mere nothingness, and foliage, on which figures are seated. In another place we have demi-figures issuing from flowers,

some with human faces, others with the heads of beasts,—all things which are not, never have been, or ever can be.” And further states, “that painting is to be esteemed only so far as it represents truth, good execution, and the design be consonant to reason.”

The Arabesque style may, at first sight, appear fanciful; but, no doubt, it may be treated according to fixed principles of art, and the artist will be more successful as he keeps those principles in view. A due



balance of composition is very essential, that the heavier parts may sustain the lighter through every gradation (as I intend illustrating), and not to cover too much or too little of the ground.

Unity of design must be studied in connection with each other; and should, as much as possible, tend to some decided end. It would be deviating from my original advice to enter upon the subject of colours; but, observe, that in ancient decorative painting of this de-

scription, the beauty existed by the balance of colour being strictly attended to. Their walls were chiefly of dark panels, with various lighter colours, according to the designs upon them; their ceilings, were, likewise, arranged by the natural effects of light, shade, and reflection. As lightness and grace are the peculiar attri-



butes of Arabesque, the foliage, which forms its most fertile resource, should never be overloaded; its details, and modes of ramification, ought to be drawn from nature. Foliage and flowers may be represented with the greatest accuracy in these decorations; as one single flower, gracefully formed, with a little scroll, will form a picture. Small fountains, ovals, and circles, containing subjects of interest.

Portraits and medallions may be introduced. The leaf is generally of the deeply *serrated acanthus*, long thin stamen, and starting points, terminating with cup-bosses, holding some sort of tablet, that baskets of fruit or flowers may be placed thereon ; long starting volute scrolls



from each side of a reeded and cupped pedestal, or small columns, composed only of figures and bases. In fact, any slender object may be used, that will fall gracefully into a variety of forms.

I have introduced a few small pieces, as diagrams, of the leading feature ; but, of course, by study and attention, you will be able to form an infinite variety of patterns, being careful to adhere to the previous remarks. Your next attention must be to the colouring ; for the character of the style is not sufficient by itself,

but requires the aid of an infinite number of colours to shew the effect, and in that department it is out of my power to give you instruction; but there are so many examples of pretty colours, that I am of opinion there is no need of so doing. In fact, it is the study of many to arrive at perfection in producing effect without a thorough knowledge of drawing, and by very simple means; yet I never could find sufficient courage to pay any attention to that department, but always strove to produce light and shade without any variety of colours, and I would advise others to do the same; and, if nature should have bounteously bestowed on them an overpowering *development of colour*, as phrenologists term it, you must reach the apex of perfection. The best specimen of colouring, of this description, I have seen, is at the Pantheon, in Oxford-street, where a day or two's study will be sufficient; but, previous to your proceeding with your glowing tints and gaudy effect, learn well to shape your orna-

ment, and plan your designs, and the other will, no doubt, very soon follow.



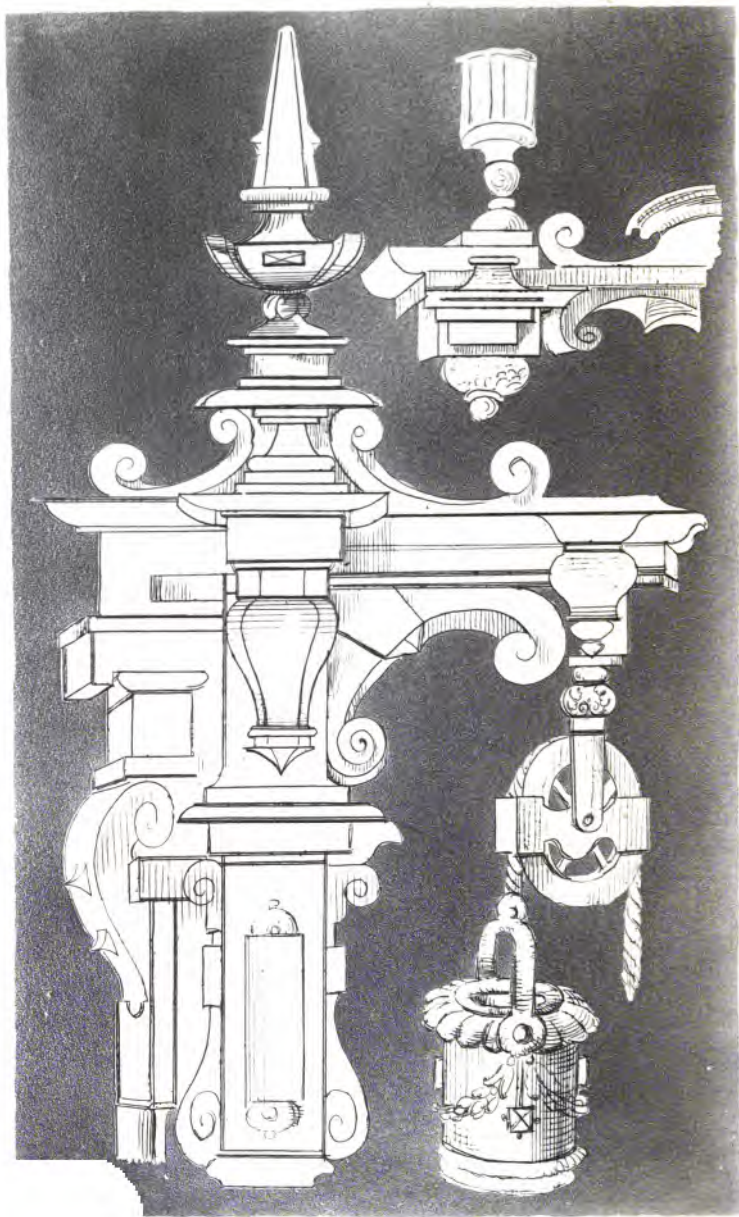

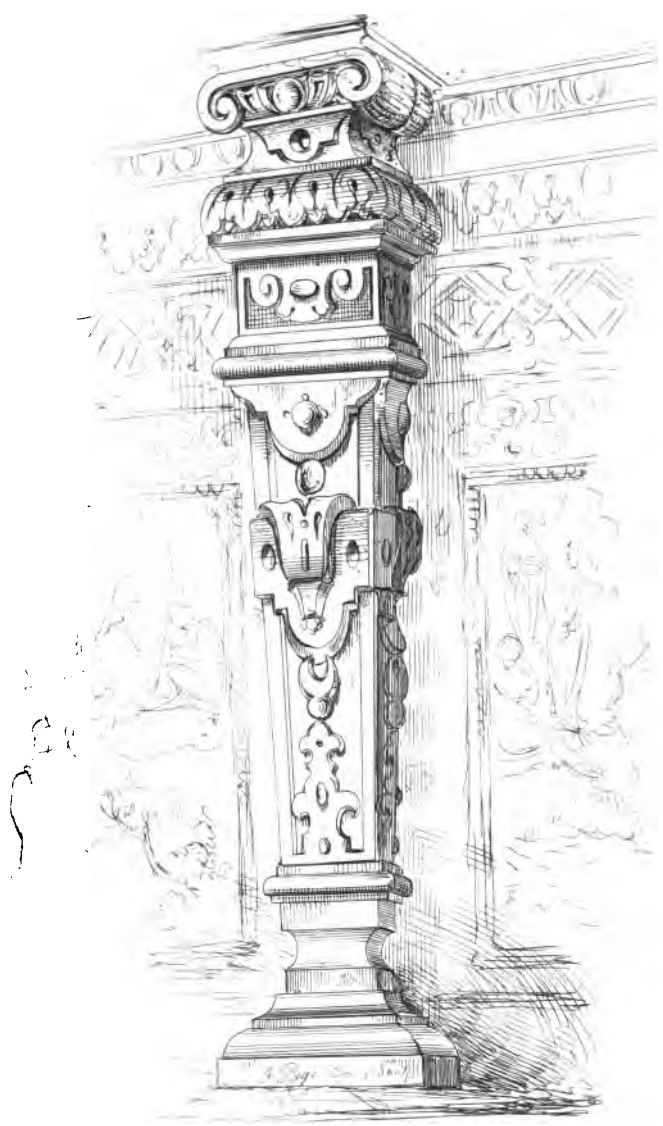

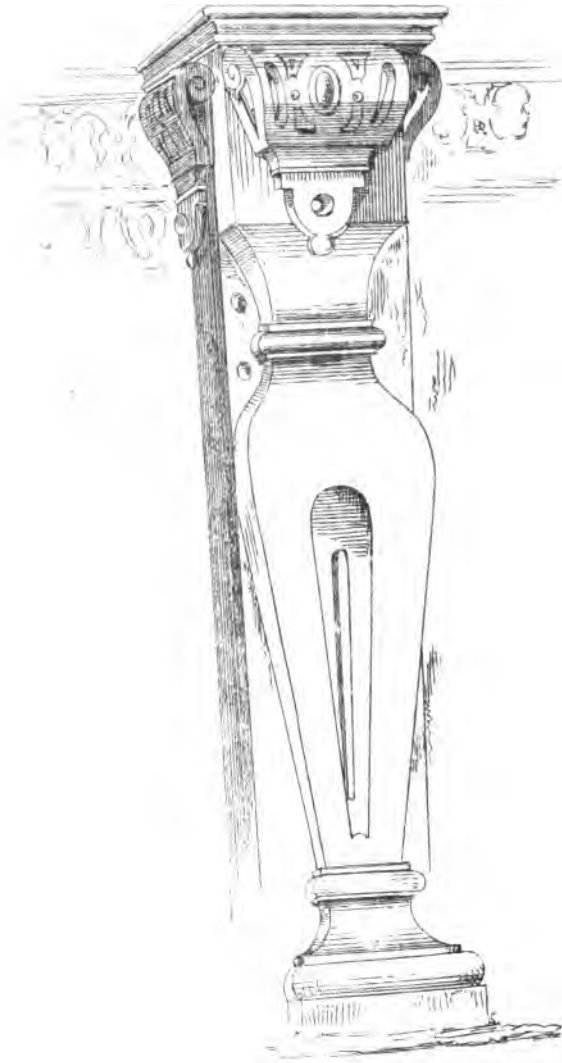





THE general outcry, at the present day, for this description of decoration, involves on me a task not easy to compete with, as regards giving a decided opinion respecting the true character and date of its introduction into this country. I know not of any style of decoration and building, on which architects and authors have differed more widely; under these circumstances, it will be my study, in this instance, to bring all accounts together, and, if possible, glean that substance on which I may base those principles, that the Elizabethan decoration may be formed into decided laws and rules, for classing it as an established character or style.

As I have stated, my intention is, in this instance, if possible, to base the Elizabethan architecture and decoration as a style of itself; and previous to illustrating too extensively its component parts, except where necessity requires, I shall give a brief account of its origin, progress, and detail. The successful travels and researches in ancient and modern times, for the improvement of art, has, no doubt, been the cause of so many variations in the different styles of architecture, at the present day; not that it is my intention to enter into the various orders of architecture, but, in this instance, I must appropriate a few lines upon that subject, to bring my ideas to a bearing. We are informed by many, in fact most architectural authors, that we are in possession of five distinct orders to class our building and internal decoration upon;—that may be very well; yet, out of those, if you think proper, you may make fifty more; and, for this very reason, I class the Elizabethan as an order of the latest period, or *decorated Tudor*, particularly in the

variety of its forms and component parts, let them be copied from whom, or wherever they may, or however displayed, it is these items that constitute originality, whether good or bad; and, as I before stated, with the five orders of architecture, we have the *Tuscan*, *Doric*, *Ionic*, *Corinthian*, and *Composite*;—thus far, so good.

Now, what visible difference is there between the *Tuscan*, and *Doric*, or the *Corinthian* and *Composite*,—that is the point; and, before you give your ideas too freely, you should consider that the first principles and rules for diminishing and designing of columns were laid down by the Grecians, who were the inventors of the three distinct orders,—all different in appearance at one glance;—the **DORIC**, the **IONIC**, and the **CORINTHIAN**. The annexed illustrations will prove the variety, and shew at once the inventive genius of that country.

After making yourself acquainted with their appearance and names, you never can mistake them at first sight, but you may clash the

Tuscan and *Doric* as one, or the *Corinthian* and *Composite* the same, there being such similarity between them. Now, the *Ionic* stands without a rival, except being plundered by the Romans to murder the appearance of the *Corinthian*, as an attempt to claim an original order of their own, in that, as well as in the *Tuscan*. If this piracy is allowed in the architectural



Doric.



Ionic.

world, as an original order or character of itself, there are, I am sure, many better and more original designs to be gathered from some of the old Norman and Saxon cathedrals, than are shewn by the Romans in their *Composite*, which is done, merely by robbing the *Ionic* of its grace, and the *Corinthian* of its richness. I here give a small illustration of the *Composite*

chapiter, that you may not be at a loss to understand my remarks, and shall now proceed with my ideas respecting the Elizabethan. As the wreaths of originality are allowed to the Romans, by their combining the Grecian order to make one of their own, and are given credit for the same, why not do so with any other



Corinthian.



Composite.

that works upon the same principle, although it cannot be expected ever to meet with the encouragement of the Roman orders, or do I wish it; for, on looking at their structures they seem transparent, (*if I may use such a phrase,*) that you immediately recognise Grecian art within them, which art has never, or

ever will be, obliterated, or surpassed; and, as originality is recognised, chiefly by variety of forms, I cannot do better than give a proof of the same; for instance, I have given an outline of four different descriptions of buildings,—the Pyramid of Egypt, the Temple of the Parthenon, St. Paul's Cathedral, and York Minster. Here is originality and variety of



form, that being required in decoration of every description. A variety of external appearance, if properly displayed, is sure to attract the attention at once of the passing observer, or the connoisseur; and, in no instance can it be more practically brought forward than in the Elizabethan, which contains a greater variety of forms than any other class of decoration in use. The earliest specimen, bearing resemblance to its internal appearance of

decoration, I have seen, is dated as far back as Henry the Eighth. Other prototypes are in the cinque-cento, or Italian, the Germans, and many others; but most likely the originators, or compilers, were artists of our own country; and it is my opinion, that the Elizabethan is that which succeeded the perpendicular style,



and was practised until the reign of James the First, and was the standard style during the sixteenth century. I consider its course was shortened by the powerful imagination of Inigo Jones, who, by-the-by, had a small share in it, as the gateway of Whitehall, which has been removed some years, was designed in that style; but it is also asserted to have been from the

pencil of Holbein. By Walpole, and many others, the style, which we call Elizabethan, was termed, in derision, King James' Gothic, being of itself so compounded and heterogeneous; and we have no reason to disbelieve otherwise, it being a compilation from foreign artists and foreign styles, at the same time not forgetting to take advantage of the fixed orders.

The earliest and most successful effort in attracting the attention of the admirers of the arts, was the ceiling at the Chapel Royal, St. James', painted by Holbein in 1540, shewing a decided proof of his taste and architectural skill; and the result of all his imperfectly directed efforts of genius were such, you might perceive a grandeur and richness, combined by the effect of the grotesque and eccentric; and its character is of that description, to appreciate its beauties, (*if it has any,*) it must be studied by an unbiassed mind, and requires a very careful examination, before the complexity of form and enrichment can be well understood.

The following style is deceptive to many persons; for wherever gables, ornamental finials, pendants, oriel, or projecting windows, and pinnacles, are seen, it is immediately termed Elizabethan. There you are wrong, — all these addendas are formed on the basis of the old English school, or, more properly speaking, domestic architecture; but the theory on

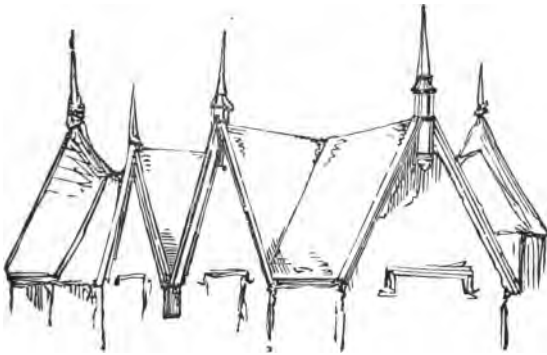

Gable-end Roofs; or, a number of Triangular Roofs, springing from various directions.

which Hakewell and Richardson would fix the pure Elizabethan, is the cinque-cento of Italy, unmixed with any Gothic detail or Gothic enrichment. And they are certainly correct to a certain extent, otherwise from whence do

they make use of the pinnacle and finial, although not exactly of the Gothic form. Still it has a resemblance; and, as before stated, it being of itself but a compilation wherever we trace a figure most prominent in any other style. Of course, we are at liberty to accuse



Gothic.

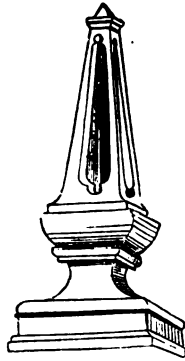

Elizabethan.



Norman.

them of pilfering from that, or from others; but, to place before you a correct notion of the Elizabethan architecture, is to strip it of all those hideous and grotesque forms, which, in its progress, overloaded it, and refer to it in its pure and original state; we shall there find it

combined of Roman orders, and mouldings purely the same, enriched in various compartments, of a sort of mixed fret-work, and forming

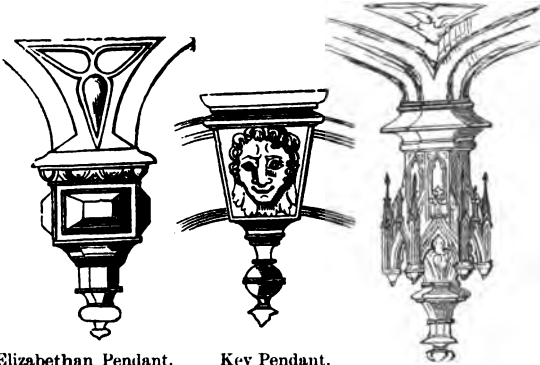

Elizabethan Pendant.

Key Pendant.

Gothic Pendant.

a style particularly adapted to street architecture, and may be either simple in its appearance, or ornamental in the highest degree, (this, in my opinion, is its original character;) but, in the reign of Queen Elizabeth, there seems to have been no lack on the part of the artists to add grotesque forms, as I intend illustrating. My opinion is, that her pride and will was such, in building, could it have been executed with propriety, that houses, palaces,

and halls, would have been covered with precious stones ; and, as that was out of all reason, the favourite artist in those days, John Thorpe, added carved enrichments, to imitate the same. The pure specimens of his drawing, &c. are in the Soane Museum,—and a grand collection



Bay Windows.



Oriel Windows.

they are,—not only ornamental designs, but architectural elevations, in which he has shewn great skill and taste.

My first endeavour to illustrate the Elizabethan, will be to anatomize the various features and peculiarities, as regards the decorations ; not as regards its architectural eleva-

tions and measurement, but give you that portion, that you may not be led astray by

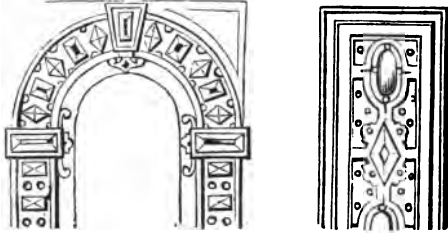

every grotesque form that meets your eye, to call it Elizabethan. For instance, I am sure, in many of my future illustrations, you will be apt to think me going beyond the point of



reason, when I introduce the Roman acanthus scroll, the honeysuckle, (*purely Grecian,*) Gothic pinnacles, and the orders of Grecian architecture; yet all these combined, without grotesque form, are Elizabethan; but as I before remarked, that when, as some would

Colonel Cust,) of the internal fittings at the Star Chamber, or King's Palace, which he had fitted up at his own mansion, as it stood in Old Palace Yard, Westminster. The ceiling of that was most elaborate,—it was purely Gothic; and, at each extremity, terminated with the white and red rose of York and Lancaster; the port-cullis, and the pomegranate, which, with



Rose.



Fleur-de-lis.



Pomegranate.

the fleur-de-lis, was a very favourite ornament of that time.

I have given one of the small compartments of the ceiling, as well as a portion of the decoration around; or, more properly speaking, the screen over the fireplace. It is intermixed with Grecian columns, pilasters, circular-headed panelling, the mixed fret, and Arabesque, combined. The consoles, or soffit brackets, were



of a very curious description, chiefly of an eccentric section, and terminating with pendants. Grotesque and scroll shields, to contain their armorial bearings, were very much used; the

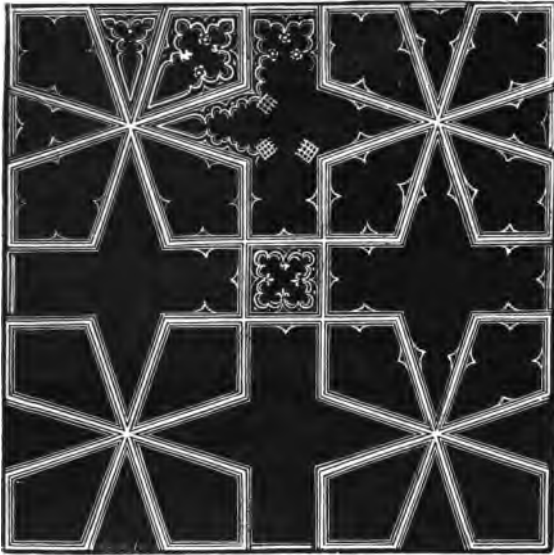

Ceiling of the Star Chamber.

ceiling, chiefly moulded in different geometrical forms; the panelling very richly moulded, and forming figures, terminating with an immense number of angles, which, when of polished oak or wainscot, gave a very bold appearance

and richness combined, as very little furniture was used to detract the attention of the internal fittings.

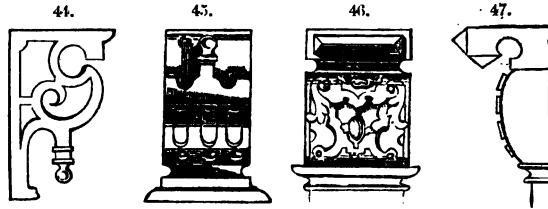

I shall now draw your attention to consoles and soffits, as illustrated in fig. 44, 45, 46, 47, 48, 49, and 50. Fig. 44, is from the Star Chamber; you perceive, by the section, the eccentric form as before spoken of, and it has a very light appearance in this view; but in fig. 45, being the front-view of the same figure, you perceive a heaviness which prevails in the whole of them. Fig. 46 is another description, having the form of an Italian circular frieze, adorned with an imitation of a cut stone, and small scroll shield. Fig. 47 is the front-view. Fig. 48 is very rich and proportionate, it is from the pulpit of North Cray Church, erected in the year 1637; it is one of the most graceful

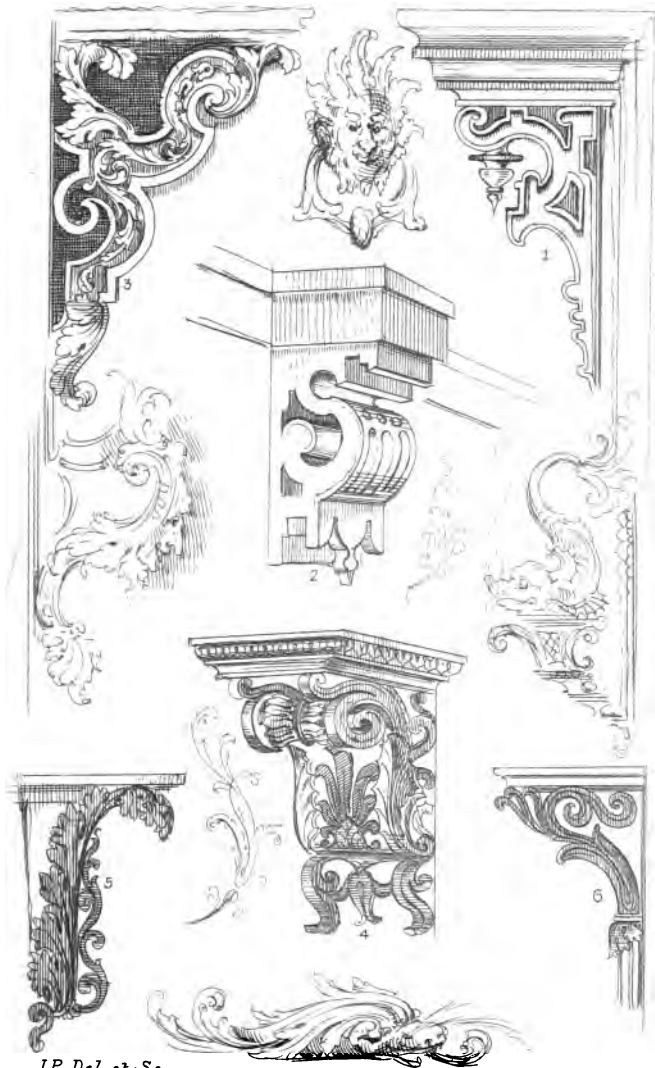

I.P. Del et Sc.

1, 2, ELIZABETHIAN, 3, TUDOR, 4, 5, 6, GRECIAN

forms I have seen of its kind or style. The section, fig. 49, still carries that perforated character, but not to an extent that many do; the front does not seem to overbalance the

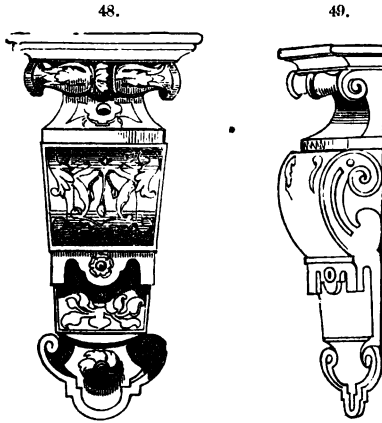

side: this is a very excellent study, and the most likely to have been executed when Elizabethan was in the zenith of its glory. Fig. 50, is from the same; and you might almost arrange this with the Grottesque, or semi-caryatides, but here it is in character with the edifice: the figure seems to represent Old Father Time, with the scythe in hand, and

the hour-glass over his head; these trophies speak volumes in themselves, and seem to say, that, when my glass is run, which is set for all men, then will I cut thee off like a shadow. I merely mention these points, to draw your attention, that, however grotesque many forms may appear, yet, when well read, there is always a history or good meaning to be placed on the ideas of the artist, however deficient he might have been in point of execution. Of all the specimens I have seen, this outvies



all for symmetrical form. The plan is of a pentagonal figure, and the erection is composed of moulded panels, Ionic pilasters, enriched consoles, and carved enriched cornices and mouldings, an enriched back board, with circular-headed panel, and carved, as I before stated, in imitation of jewellery. The sounding-board has a blocking course, consoles, and pendants; in the panelling are enriched scroll shields, or tablets; and on one is carved the date of its



erection. I intend illustrating, in detail, the various ornamented scroll shields, upon it; and, in the annexed plate, I have given you a mere sketch of the form and exterior outline, which, with the detail, I am sure, will be sufficient explanation of what I consider the purest specimen of Elizabethan carving and wood erection of the kind in this country.

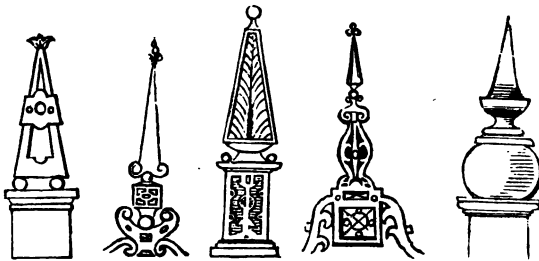

I shall now refer to the pinnacles: these were generally square, some solid, and others perforated in the form of a circular lancet Gothic head, and mostly separated from their base by four round balls, and bound round the centre; others of an eccentric, and some starting from scrolls. These ornaments were used in interior decorations, as well as exterior, and

formed prominent features at the extremities of gables, as will be seen by the previous illustrations; but they were generally of a slender form, and shews more conspicuous by the several indentations at their base. To add effect to many minor decorations, I have seen pinnacles starting from the scroll turns of a shield, and at the angles of various projecting ornament. I have here given you a specimen of one, which is quite sufficient as a guide for all the rest.

You will perceive in the accompanying

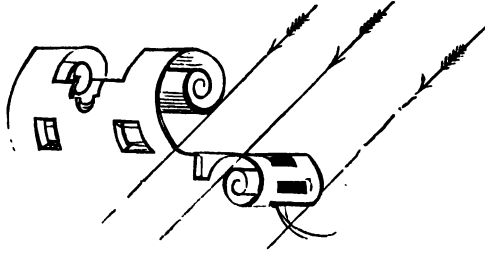

diagram, in reference to the descriptions of scroll used in these points, that they are not what is generally expected when the word scroll is named. These scrolls were like the folding, rolling, and unrolling of paper, by

which great richness of effect may be produced; for instance, the foregoing diagram is the principle that seems to have been worked upon. Suppose you unroll a sheet of paper; or, if you like, we will imagine this diagram to be a sheet of paper, rolled the reverse way at each end; loose it and it will produce that form. When this is done, it will give you the proper form shewn; but yet there is that powerful effect gained, which you cannot obtain very easily by any other means. In the first diagram you will perceive a dotted line. Now, suppose the light falls from the direction of the arrow, the ray of light produced by the sun is parallel, and, of course, falls in an oblique line to B. This shews, that, greater the projection, (*providing in reason, or you might throw the whole of your object in the shade,*) you have a greater effect, and the reflective tints will cause a rich appearance in all the embossed parts, as the second diagram produces, for the chief portion of these panelled shields seemed to have obtained a predominancy solely for that reason,

as I described in the foregoing diagram, by lines, which the following figure will shew shadowed, and point out exactly the principle always to be observed, and the most complete basis to work upon. In designing this description of shield, it is not by putting a con-



fused jumble of turns, or scroll-heads, because that would be wrong;—the general forms to be observed, are—oblique lines, squares, ellipsis, and right-angled figures, bands, or garters, with various shaped perforations; and are sometimes bossed with scroll-heads, which I shall now commence delineating, and likewise explain my illustrations in as explicit and simple manner as possible, for you to arrive at the right method for designing the same.

The first of these illustrations is the ob-

long square, being frequently ornamented with the angled diamond, or lozenge, and at other times with the elongated square, chamfered off, as it is usually called, to an obtuse angle of about one hundred and twenty degrees; any thing beyond that would throw off the desired effect, and produce too prominent a feature, and detract the attention from the surrounding decorations. This figure is sometimes flattened at the top, as the annexed illustrations shew.



Fig. 51 is the rake of the angle generally to be observed, and the dotted line shews about the quantity to be reduced for the flat surface.

I will now take the ellipsis, as the second description of centre, which is

51.



Rake of Angle.

sometimes confined to bands alone, particularly in that de-

partment termed the bolted style; in others it has a boss, or scroll flower; and often the cen-

tres are formed in the figure of a radiated shell, with fillets between. The annexed diagrams are the forms I have alluded to.

These shapes chiefly compose the centres, and their exterior forms make the greatest va-

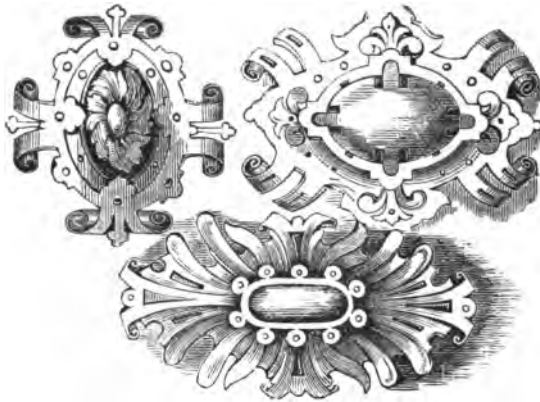

riation, the component parts of which I shall next treat of. They are the surrounding scrolls, as before-mentioned, and the ends are frequently mounted with scroll cups, &c.; these with the others combined, form the various shield panels generally seen, a few of which are compiled in the annexed plate.

The first I shall treat upon is the turned

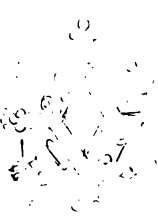
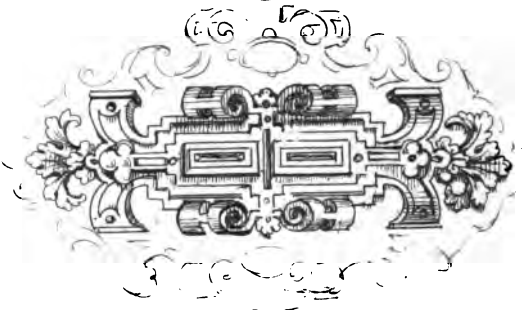
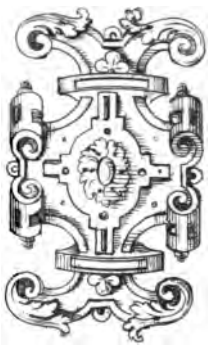

and perforated head, fig. 52, being of itself a perfect scroll, the dotted line shewing the perforation. Fig. 53 is more perfect; the dotted line only shews where you must start for the under line which is connected with it.

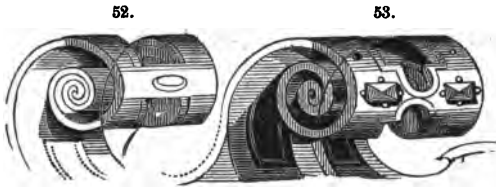

Previous to illustrating any further, I will explain to you the difference between this and Louis the Fourteenth's, in which the scroll-head has been treated upon variously; but, to prevent any misunderstanding on your part, it is necessary for me to inform you, that the turned scroll-heads of Elizabethan are always parallel, except in extreme cases; that is to say, perfectly free from what are termed ribs or fillets, except in the surface, which being in the Elizabethan, and not in the French, as the two diagrams shew.

This is worth your particular notice, as

their similarity is very likely to lead you astray, but as I mentioned before, *only* in extreme cases, which very seldom occur. It being my duty to give all I consider useful, I shall next draw your attention to the form consisting of two fillets, with a bulbous scroll-head in the centre, and rarely used without a scroll, or bearded ends accompanying it, (of which I treat next,) and are termed the elongated pan-



elled scroll, fillet scroll, and perforated, and seem as if bound with a band, to prevent their growing or spreading too wide apart; and although these panelled ornaments are composed of single straggling pieces, yet, at the same time, in putting them together, there requires the greatest nicety to compress them into an agreeable and graceful shape.

The following diagrams are the general figures of the spreading ends; and, before I

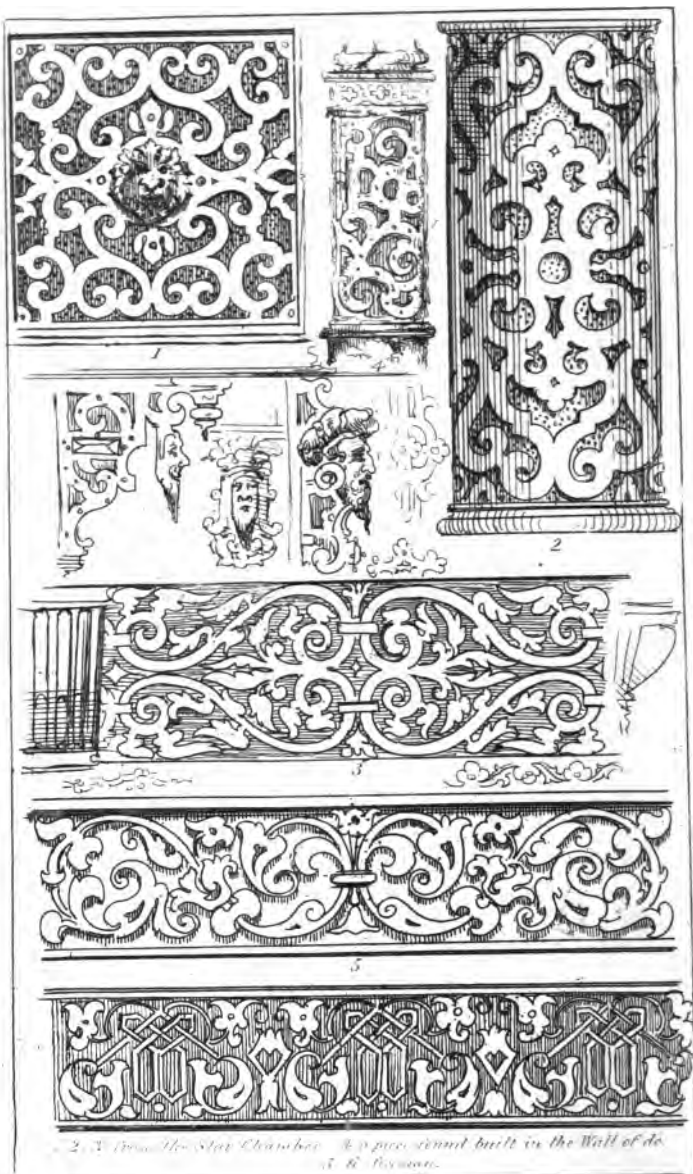

leave this portion, I will give a few of the centres, which are attached to the same; and when all are combined, (as you can refer to in the plate,) you will, no doubt, see the utility of my



Elongated panelled
End.

Circular Head,
Beaded.

Scroll Head, used with
Bulbous Scroll Centre.

thus classing the different parts. The first, or most simple, is the bolted end; second, the cup and flower end; the third, the trefoil end.



Bolted.

Cup and Flower.

Trefoil.

I will now take up another prominent department, namely, the entwinement of perforated fillets, or mixed fret-work, of which there are two kinds, pierced and bolted, and

in some instances it is most lavishly used, and the conclusion generally drawn by the common observer, is, that wherever this is seen, it must be Elizabethan. This ornament was usually placed at the top of houses, and over various elevated positions, where there was sufficient scope; but that usually placed on the top of the different projections in front of various halls and seats, is generally termed

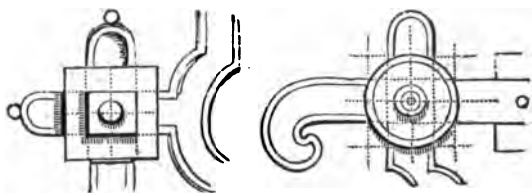

the bolted style,—the difference between that and the intermixed fret, or pierced work, I now intend explaining.

The bolted style, as I have before stated, was mostly placed on the top of the front and end facings of mansions or halls, and was composed or designed on the same principle as the intermixed fret, but that, in a lofty position, looked meagre; so, to prevent that ap-

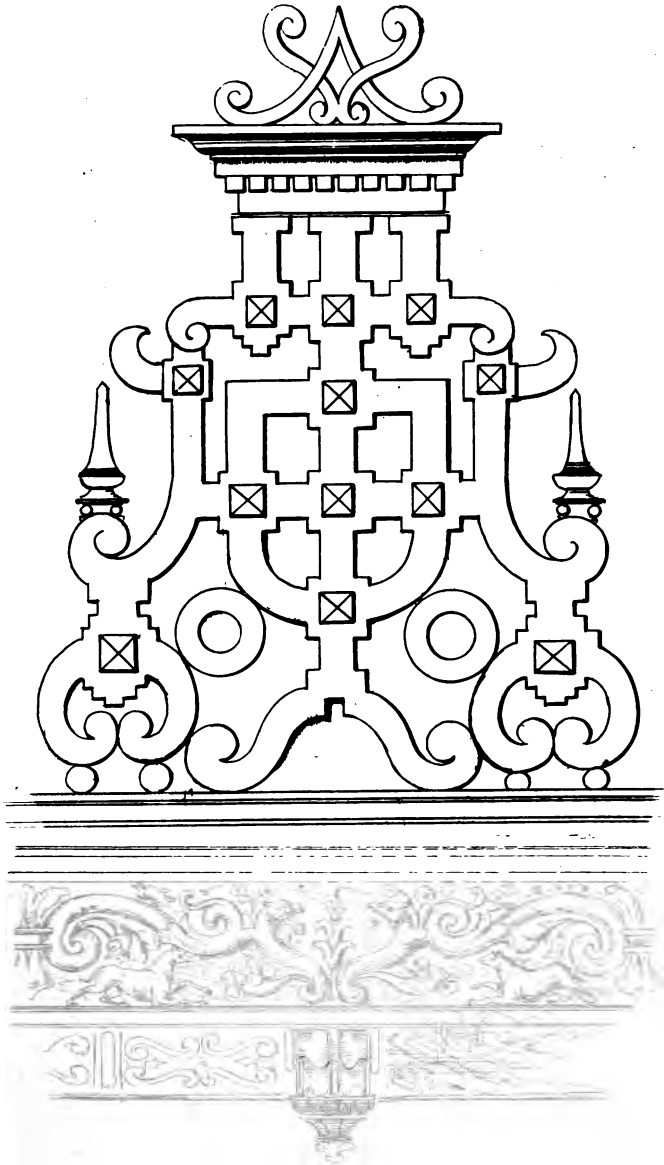

pearance, the forms of square and round-headed bolts were placed, to appear as if the whole of the outer work were morticed and bolted together. The general principle that seems to have been practised, was allowing the square and circle (from whence started the various perpendicular and horizontal bars) to be double the width of the bar, as the previous diagram:

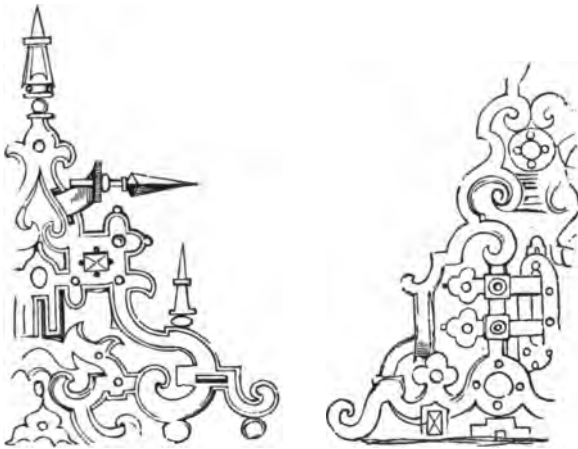

and however complicated the form may be, yet the above is the plan to be observed throughout. The number of different pieces that composed this were few, but it was the intermixture and repetitions that caused the variety.

I have now given you, by small illustrations, a few of the leading points, in fact, almost all; and you must be careful when designing this description of ornament, that wherever you have a square department, or the formation of a shield, that all your smaller squares come opposite each other, as seen in the foregoing diagrams; if you do not, it will not only be entirely wrong, but at the same time look very bad.

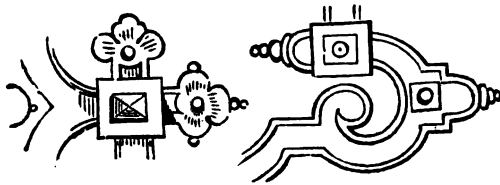

Further illustrations of this kind you will perceive in the accompanying plates; and I shall now treat on the pierced, or mixed fretwork, which was most commonly used in every department where decoration was required, even surrounding the whole shaft of a column, the facings of pilasters, and the different portions of panellings, but more particularly on the upper extremity of cornices, a very peculiar appearance is given to this ornament; and,

when pierced and backed, the ground-work has a frosty effect, done with a small round punch, and at other times merely circular holes, at intervals, as the annexed diagrams. The addition of this ground-work is peculiar to itself, and,



is seldom or ever found in any other description of decoration or carving, or scarcely used where the bolted style is introduced, because it would detract the attention from the appearance of the face of the ornament, which, when carved on the frieze of a room, looks very well, with intervening soffits and block cornices around, circular-headed doors, windows, and spandrels. All this is in character to a certain extent, if not profusely used, to compose or design this kind of ornament.

I will now explain the intermixed perforated fret-work, which is composed of the eccentric scroll figure and plain volutes, intersect-

ing points between, keeping them at a proper distance, so as not to jumble the whole together. All these are joined by perpendicular and horizontal lines and right angled bars, sometimes terminating with a paper scroll-head and jewelled centre, and surmounted with pinnacles and bases, various little bosses, and corded laurels or flowers intermixed. Of these various portions you will find outlines in the adjoining plate, merely as plans for you to design upon, and fill up. These may, in some instances, be surrounded by a fillet, (but not too broad or too deep, that it may have the appearance of a great hollow,) and in other instances it may be bevelled off on each side; which, when closely grouped, add greatly to the variety of effect.

All these points, you will perceive, are attended to, as far as necessary, in the accompanying plate; and will conclude with giving a few illustrations of another prominent feature of earlier times, and which go conjointly with my previous remarks, viz.—the carved oak

and moulded ceiling; and, in some instances, I consider these portions of decoration gave the

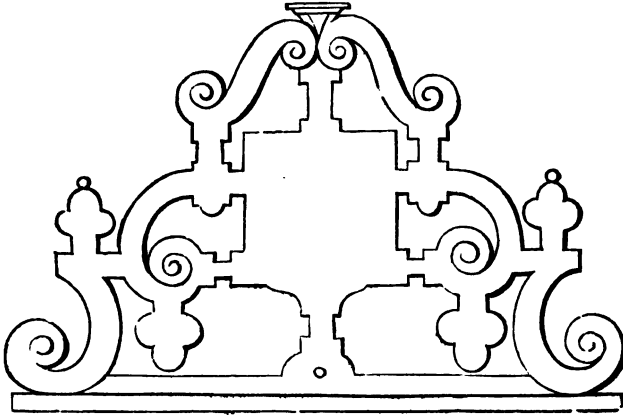

greatest opportunity for the display of Geometrical study in all architectural ornament, more than any thing that could possibly be thought of, and must have caused an immense opening for study, some of them being of a complicated form and variety of figure. I have introduced a few of them, leaving you to form others of your own, which may very soon be done, by laying down a rule, as I have added to some of the annexed illustrations.

Fig. 54 is a portion of the ceiling in Queen

Elizabeth's room, Dorton House; Fig. 55 is from the Sexton's House, St. James', Bristol; Fig. 56 is from a farm-house, once known as the Duke's House, Bradford; Fig. 57 is from the same house, in the upper floor.

54.



Dorton House.

These explanations are all I think necessary to complete this portion, but will give an illustration of what I consider the origin of this

curious kind of decoration, which it certainly is, and not very easy of comprehension, or to retain in your memory;—the piece I allude to is on the annexed plate, taken from an

55.

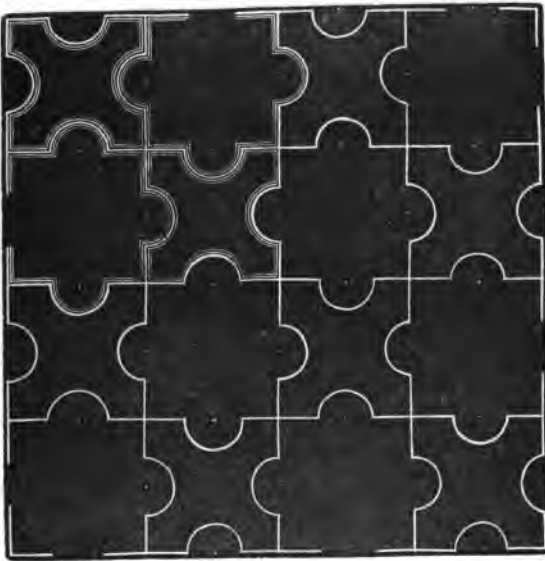

Sexton's House, St. James', Bristol.

old steel lamp at Nuremberg, dated 1586; it seems, in this instance, to have been in a very imperfect state to what it was brought to a few years after; still, here we have the sup-

posed original, and we should always look to that point with delight, as we can, no doubt, improve, but should always maintain the character and form of our first model, however

56.

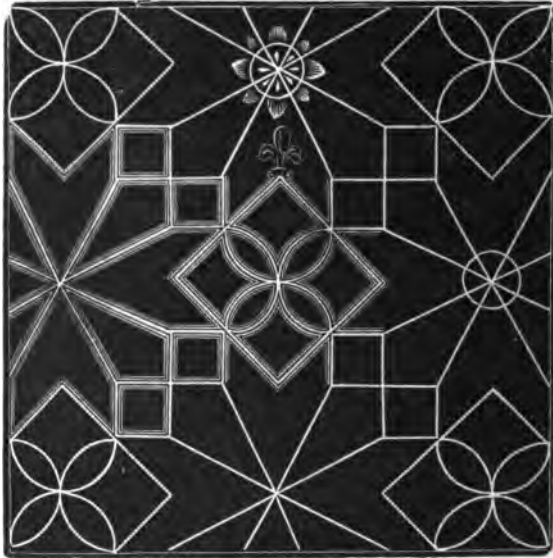

Duke's House, Bradford.

ancient; and, if we wish to renovate or call back that same style, it must be according to the character or manner in which it was executed. Although the arts have been so

much improved of late, it is but in altering and forming the geometrical proportion more graceful, on which we ought to trespass.

I will now leave you to your perseverance,

57.

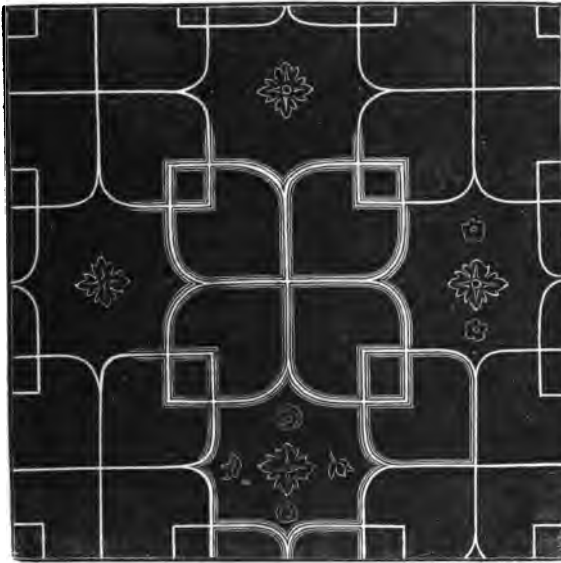

Duke's House, Bradford,—First Floor.

in combining and accomplishing the true feature of Elizabethan, as far as the ornamental department extends; and, should you require to proceed further towards the architectural

portion or plans, I cannot do better than refer you to Richardson's and Hakewell's "Elizabethan Architecture," both as regards external and internal fitting; fully assured, that there you will find all you require to complete your ideas; but the portion I have treated upon is merely to found a basis, or taste, whereby the ornamental draftsman, or student, may use his or her discretion as to the simplicity, or however elaborate the plan or idea may be; at the same time impress on you, it is a style peculiar to itself, and when used with judgment, and in its proper place, it is very well; but I would not have you waste your ideas and time too much upon one style, but learn of what it is composed; and after that, treat with it as your judgment guides you, when it is required, as it is a bad plan to make too free use of only one description of ornament, which will throw you off your principles and ideas of other kinds that you may have studied. Thus, having made yourself acquainted with all my foregoing remarks and principles, which, if properly paid

attention to, must inevitably repay you for the perseverance, labour, and study it may have cost you. And I again caution you, let not your mind be led away to attempt building a mansion before you can plan a cottage, but go on gradually, from step to step, and study well all portions of the art that are good, but copy little, with the exception of that which you may have retained in your memory by looking at others. After that refer again, and study to make yourself acquainted with the ideas and styles of foreign draftsmen, from whom we have derived the chief knowledge of a variety of styles in ornament, and have in many instances improved upon, *but more often spoiled them*; and why? merely for the want of that scope which foreign schools throw open to all whose minds are fixed for perfection in any particular portion of the arts; and, before we can arrive to that, we must fully make up our minds to defy competition, by having a true school of design. It is only the want of will, and not of mind; for I am certain, were there

sufficient scope thrown open to the British student, with unbiassed limits of instruction given, and tutors properly selected, for a strict adherence to the same, that our country would, in a very short time, laugh at foreign artists as designers, and should only have to thank them for their original principles. Then we should have the pleasure of hearing and saying, that those whom we have for years been obliged to copy and obtain designs from, will be glad to take advantage of our superiority over them,—not only in design, but novelty of invention. To remedy all this, schools of design should be formed in different manufacturing towns, and in various parts of the metropolis, so that the student may go gradually through a routine of study, and put in possession of the best examples that can be placed before him; and until this feeling operates on the public mind, (which I hope it will shortly,) take my advice,—go on that principle by yourselves, and in time it will fully shew what can be done by proper practice and training.

I now intend completing this portion of my advice, by a trifling introduction to the Gothic rules and variation of arches, and of their introduction, which will be found essentially necessary in the course of design, with geometry.

ON GOTHIC DETAILS,

AS REGARDS CURVILINEAR PORTIONS AND PERIODS.

AMONGST the various modes of architecture, there are none more suitable and open to variety in the study of geometry and proportion, than the Gothic. My intention, in this instance, is merely to give you the universal form of the various arches, and principle for striking the same, and leave you to fill them up yourself with tracery, as you please, (*in those that require it*;) feeling confident that it is of the utmost importance in designing or copying from any principal edifice, to know, when you perceive a Gothic window, that oftentimes the greatest difficulty arises to give the true form, solely for the want of knowing how to go geometrically to work; and in another instance, it facilitates copying, in a very great measure, as regards a saving of time; because, being tho-

Pinnacle



Spandrell

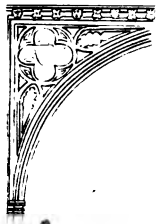

Spandrell

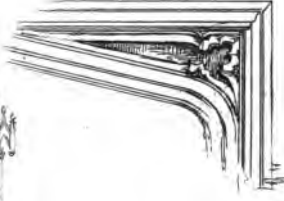

Decorated Pinnacle

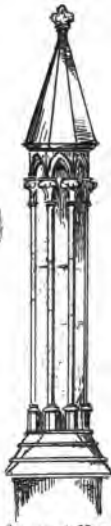
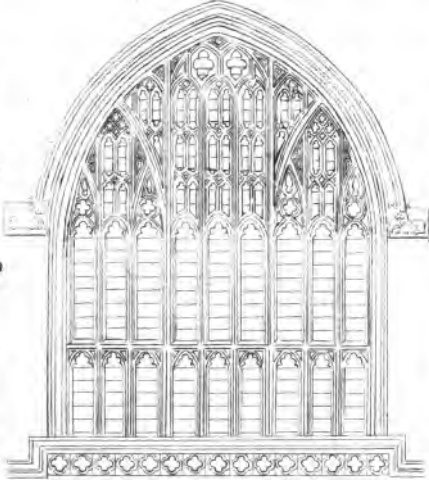

Saxon & Norman Pinnacle

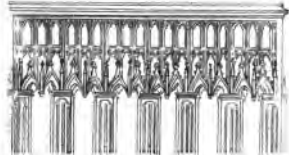

Canopy Heading



Crockets

roughly acquainted with its form and character, you have only to note it down, and at your leisure you can complete it, without further trouble. There are at present more valuable works on that topic than of any other description of architecture, so that it would be folly for me to enter upon it further, than merely giving you that which is really useful to the universal draftsman, independent of its value, as regards knowledge;—for the many scattered remains of castles and cathedrals over the various parts of England, connect it with a variety of pleasing associations, that must render it a truly interesting study. I have found it so to a certain extent, without attempting to give my time to those portions which are required to make an architect; and others, I hope, will do the same;—although it may not be required in your profession, it will, at least, give you the superior command of knowledge over many, and render you a pleasant companion, in giving an explanation of any particular cathedral, or other Gothic edifice, and in what

period they were built. The origin of Gothic was, no doubt, from the cognate race of the Saxons, Franks, Normans, and Germans; and we can easily mark its progress of improvement from the Norman conquerors; and in this case, whether correct or not, the word Gothic is likely to survive, and bear that title, beyond any other appellation, according to various styles that might have been given to it. And as, in an earlier portion of this work, I have informed you, that it is only by reading and studying different masters, authors, and others, that I am enabled to draw your attention to the most useful parts required; and where I have been able to facilitate any difficult points, I have done so, and feel a pleasure in throwing open those rules, for the benefit of all who choose to follow them.

The classification of Mr. Rickman on arches, is undoubtedly the most skilful that has been suggested, and is now generally followed. He divides them into four kinds.

1st. The semi-circular, or Norman, extend-

*Sculpture from
Rochester Cathedral*



ing in its pure state from the time of the Conquest to the reign of Stephen, A.D. 1136, and, with the mixed or transition style, which succeeded to about the year 1190.

2nd. The early-pointed, from the reign of Richard the First, 1189, down to the end of the reign of Edward the First, 1307.

3rd. The decorated, which prevailed during the greater part of the fourteenth century.

4th. The perpendicular, sometimes called the Florid Gothic,* which commenced about the reign of Richard the Second, and prevailed during the whole of the fifteenth century and the early part of the sixteenth, down to the period of the Reformation.

The arch being the most prominent and distinguished feature in this style of architecture, I shall close these remarks by a short description of the different forms of arches introduced, with the periods during which they principally prevailed. These, and many other

* Henry the Seventh's Chapel, Westminster, is the finest specimen of Florid Gothic and tracery in this country.

illustrations which may be necessary, will be treated on the most simple principles, to enable any person who can handle a lead pencil and a pair of compasses, to make himself master of their contour and method of delineation.

The Norman, or Saxon arch, is the first I will commence to describe, as it was the earliest specimen we have of the circular arch. The period of its rage was between the reigns of William the First and Henry the Second. The characteristics of the style are massiveness, twisted and capped columns, sculptured figures, and corbel heads of the most grotesque forms, and sometimes ornaments of very rich design; moulding chiefly of a zig-zag form, groining and intermingling of circular headings and columns, forming a unity of style and effect exclusively its own. Their intermixed columniations is supposed to have originated the pointed arch, which will be seen in the annexed plate; the front as well as the interior of Rochester Cathedral, offers for the student an immense opening for this kind of study. The specimens

here are of the richest description: the doorway is most elaborate, as regards sculpture; and the scroll hinges, (which oftentimes cover the whole door,) by their several ramifications, produce an effect both sparkling and rich.

In reference to the plate, A B C are plain moulded openings; D is an enriched zig-zag, and label-headed doorway, with the scroll hinges, as I before mentioned; E is an opening, with what is termed cusps introduced, and an early specimen of a semi-trefoil head; F is an interlined opening, with an arched cornice, terminating with the angled fillet and beads. These cornices were of many forms, as moulding-blocks, cables, chain fillets, &c., and sometimes with flowers.

I will now refer to the other variations, or progress towards the pointed arch, or florid style.

The semi-circular arch, fig. 1, is the only one employed in edifices erected prior to the reign of Stephen, A.D. 1136. This arch is struck from the point A.

In the horseshoe arch, of which, fig. 2 and 3 are specimens, the centres are above the line of the springing. This arch is not very common, but is sometimes introduced along with semi-circular arches, apparently for the sake of variety. Fig. 2 is a portion of a circle; but fig. 3, after arriving at the semi-circle, you carry perpendicular lines, to elongate the figure.

Fig. 4 is the segmental arch, in which the centre is below the springing line. This form is rarely combined with semi-circular arches. Its general application was to interior doors and openings, during the early and decorated periods; but even in these it is not of frequent occurrence. This is got according to the segment required, and is termed the span or opening.

Fig. 5 is the lancet arch, the height of which is greater than its width. Where this arch is used for the main outlines of doors, windows, and other openings, they may safely be attributed to the early pointed period. In



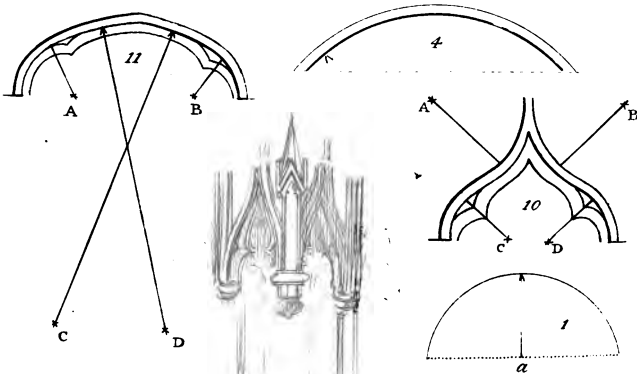
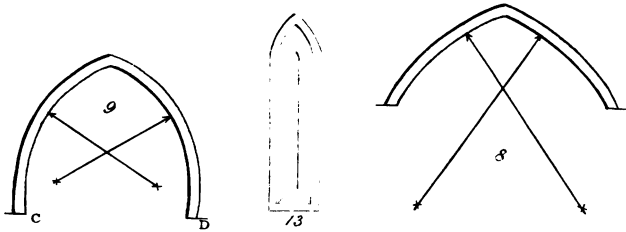
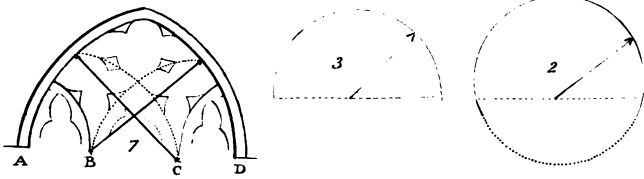
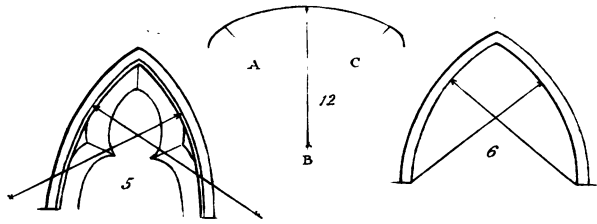

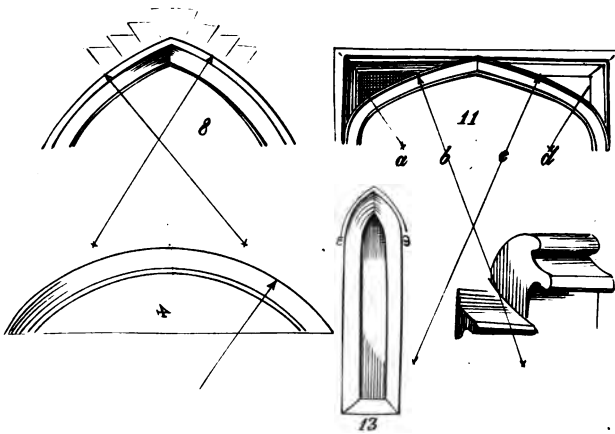
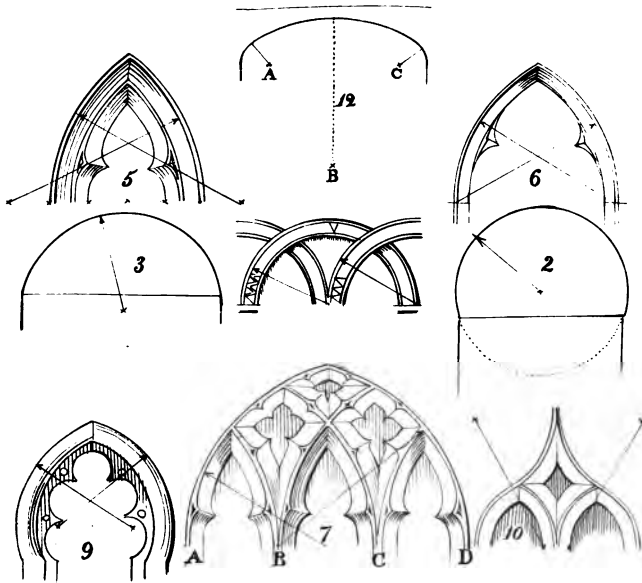

the composition of tracery and wood carving, the lancet arch is continued through all the varieties. It is gained by dividing your base line, A B, into four equal parts, and from the two extreme points your intersection will give the figure required.

Fig. 6 is the equilateral arch, of which height and width are equal, and is obtained by first getting an equilateral triangle.

Fig. 7 is the drop arch, the height of which is less than its width, and is got by dividing the base into four equal parts, as A B C D, and striking from B C.

Fig. 8 is the pointed segmental, the centres of which are below the line of springing, and bisected, as at fig. 6.

The three last-mentioned arches are used indifferently in the early decorated and perpendicular styles.

Fig. 9 is the pointed horseshoe. This form of arch occurs in a few buildings in the mixed or transition style, immediately succeeding the Norman. The choir of Canterbury Cathedral,

erected A.D. 1154, offers, it is said, the finest specimens.* Divide the springing line into five parts, and after passing the semi-circle, it immediately collapses, as at C D.

Fig. 10 is the ogee arch. This form was never used for the main arches of doors and windows of ancient buildings, as is sometimes absurdly done at the present day. Its use was confined to tracery, niches, tabernacle work, and other ornamental situations. The ogee form was also frequently applied to the canopies of doors and windows in the late decorated and early perpendicular; it is gained from four centres, as at A B C D.

Fig. 11 is the four-centred or Tudor arch. This form belongs exclusively to the reigns of Henry the Seventh and Eighth, after which time the Gothic style ceased to exist in any degree of purity. This peculiar form of arch has sometimes led to a separate classification of

* The springing of an arch is the point from whence the compass, either in a semi-circle or segmental line, touches the perpendicular line; or, more properly speaking, becomes tangent.

this period, under the denomination of Tudor Gothic ; but the mere form of the arch hardly seems sufficient to warrant this multiplication of classes. It is derived from the points, A B C D.

Fig. 12 is the three-centered or elliptic arch. This arch is sometimes, though very rarely, met with in England, in buildings of the late perpendicular : it frequently, however, occurs on the Continent, but marks the debasement and near approach of the extinction of the style ; it is obtained from the points, A B C.

Fig. 13 is generally termed a lancet opening, for turrets and air openings.

Fig. 14 is a canopy head, and usually placed over any recess, where a pedestal or figure is erected on the face of any Gothic structure.

Fig. 15 is the spandrel. This seldom occurs except in the Tudor, or low segmental arches, and is bounded by what is termed a label moulding, and usually filled up with tracery—vine, oak, or ivy leaves—rudely displayed.

It will be perceived, by the foregoing remarks, that the form of the arch is not, in most cases, sufficient of itself to determine the period or class to which an edifice belongs; but we may arrive pretty nearly, by examining narrowly the tracery, buttresses, pinnacles, and openings, (which openings were composed of various foils), and the variety necessary to be known by the general draftsman, is given in the annexed plate.



Trefoil Parapet



2



1

1. 2. Quatre Foils from the Old Star Chamber

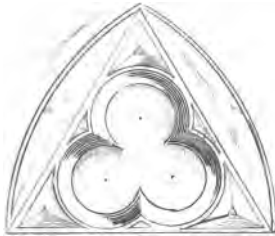

Trefoil

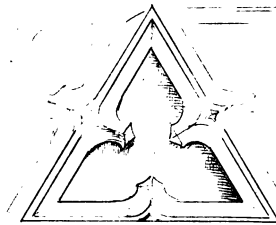

Trefoil



Quatre foil



Cinque foil

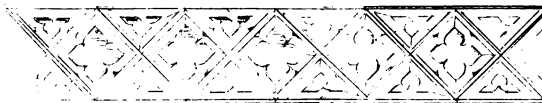

Quatre Parapet

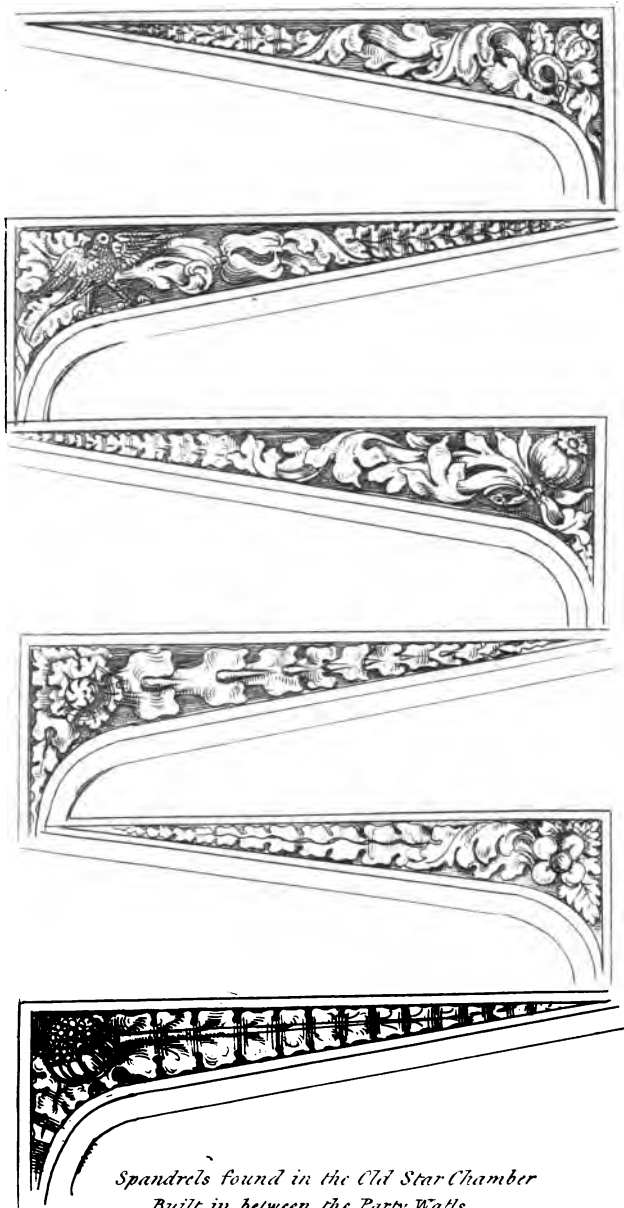

*Spandrels found in the Old Star Chamber
Built in between the Party Walls.*

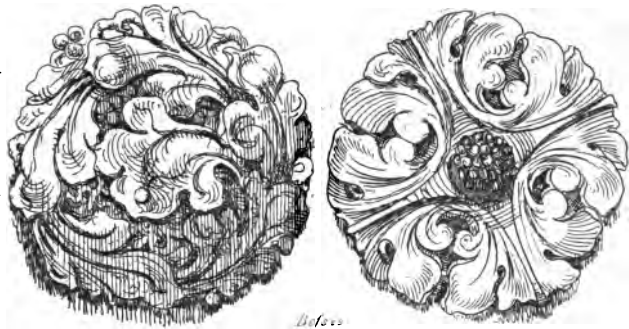

Life's

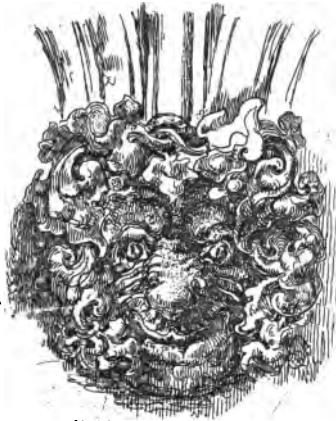

Corbel Head



Desk *lowes*

Various

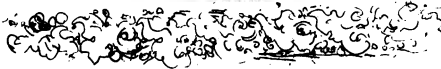

GEOMETRY SIMPLIFIED.

AN abridged history of the origin of Geometry will, I dare say, not be unacceptable to many of my subscribers, although the subject has been treated on many times before; I shall dwell no longer than I consider necessary either for the youth or student, that they may be able to answer and solve any early or useful question. The word GEOMETRY is of Greek origin, and signifies measuring the earth, or any distances thereon; it, no doubt, had its rise in Egypt, where the inundations of the Nile render it necessary to distinguish lands by considering their figures, that they might be enabled to lay them out in just dimensions and situations. Some authors assert that it was the invention of the Babylonians; others, the Egyptians; and that they borrowed it from the Babylonians. *Thales*, a celebrated Phœnician philosopher, who died five hundred and forty-

evident that any attempt at a complete conscientious treatise on the subject, would swell the present article to a most inconvenient length, and indeed would be completely incompatible with the general arrangement of the work: I purpose, therefore, confining myself to a series of useful definitions, which may be said to form the alphabet of the science. Problems, illustrative of the application of geometry to the useful arts, will be found in the annexed illustrations.

In attempting to exemplify or illustrate the following definitions, I am perfectly aware that many of my expressions and illustrations will be objected to by the rigid mathematician, but as I have before stated, that my object is simplicity, and to convey the first rudiments of this science to those who may be entirely unacquainted with it.

DEFINITIONS TO THE PLATE.

A point is that which has position, but not magnitude, as fig. 1.

A line is the trace of a point, or that which would be described by the progressive motion of a point, and consequently has length only, as fig. 2.

Superfices have length and breadth, but not thickness, as that might be unbounded; for instance, the top is the surface, as fig. 3.

A solid is a figure of three dimensions, having length, breadth, and thickness. Hence, surfaces are extremities of solids, and lines the extremities of surfaces, and points the extremities of lines, as fig. 4.

If two lines will always coincide, however applied, when any two points in the one coincide with the two points in the other, the two lines are called straight lines, or otherwise right lines.

A curve continually changes its direction between its extreme points, and has no part straight, as fig. 5.

Parallel lines are always at the same distance, and will never meet, though ever so far produced, as fig. 6.

Oblique right lines change their distance, and would meet if produced, as an acute angle.

Angles are known and measured by the number of degrees they contain at the extreme opening.

One line is perpendicular to another, when it inclines no more to one side than the other, as fig. 7.

A straight line is a tangent to a circle, when it touches the circle without cutting, when both are produced, as fig. 8.

An angle is the inclination of two lines towards one another in the same plane, meeting in a point, as fig. 9.

Angles are either right, acute, or obtuse.

A right angle is that which is made by one line perpendicular to another, or when the angles on each side are equal.

All angles meet at a point; when this is the case, each is denoted by three letters. The right angle is the criterion of judging of every other angle; $d b c$ is a right angle, $a b c$ an obtuse angle, $e b c$ an acute angle, as fig. 10.

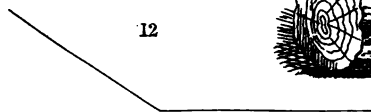
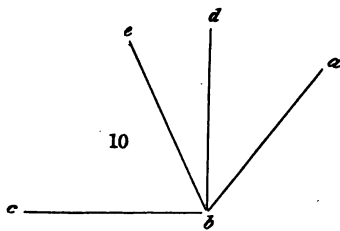
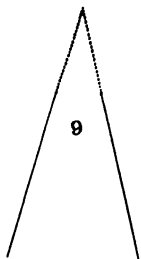
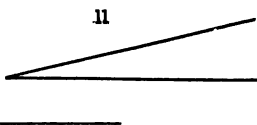
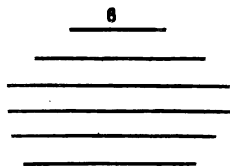
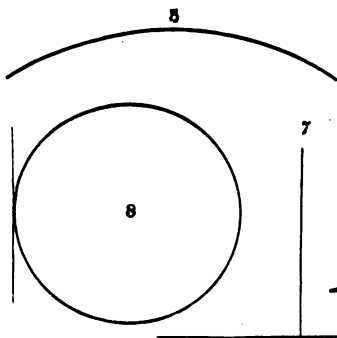
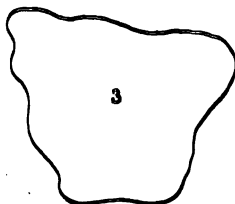
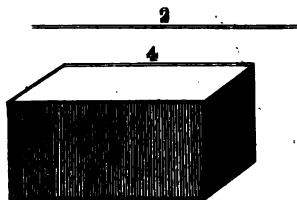

An acute angle is less than a right angle, as fig. 11.

An obtuse angle is greater than a right angle, as fig. 12.

A plane is a surface with which a straight line will every where coincide, and is otherwise called a straight surface; for instance, if I cut through a piece of timber, or a tree, the end surface is the plane, as fig. 13.

All angles are known from their extreme openings, and are divided into degrees, as fig. 16. Here is a diagram for explanation. From *a* to *b* will be an angle of 15 degrees; from *a* to *c*, 35; and from *a* to *d*, 60. These are all acute angles, being within the right line. From *a* to *e* is an obtuse angle, of 120 degrees. This diagram is on the principle of using the sextant.

An equilateral triangle has all its three sides equal, as fig. 17.

An isosceles triangle has only two sides equal, as *a b*, *b c*, as fig. 18: this is the figure of one of the principal powers in the laws of

mechanics, viz., a wedge, being made according to the power required ; for instance, a wedge of so many degrees, is measured as an acute angle of so many degrees.

A scalene triangle has all its sides unequal, as fig, 19, and is to be found in the following portion of a building, or angled bay window, whose ends are not equal to its front, as fig. 20 ; *a* being an equilateral triangle, and the two ends, *b b*, scalene triangles, forming the front elevation, as the annexed illustration.



Trapezium is a quadrilateral figure ; that is to say, a figure with four sides. In this instance every side is unequal, as fig. 21.

An octagon is a polygon of eight sides. This figure is placed here, merely to shew the prin-



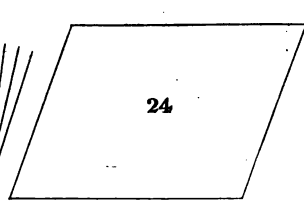
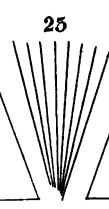
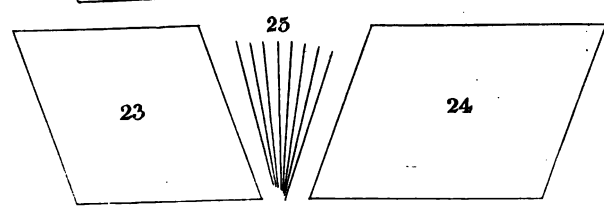
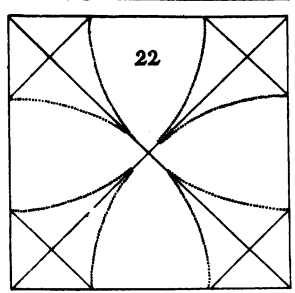
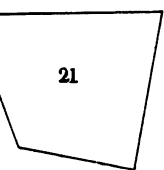
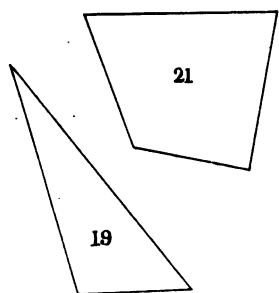
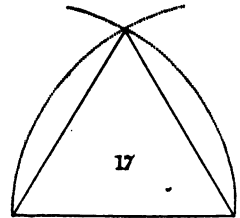
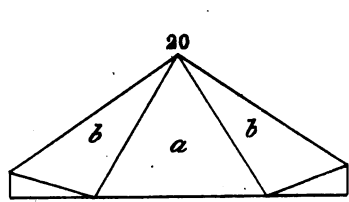
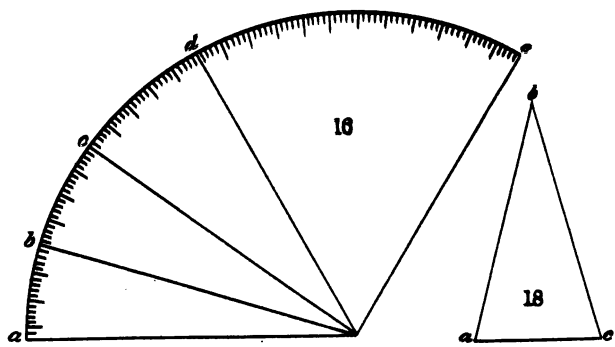

principle of gaining it. First form a square, and from each angle or corner you strike a segment, whose arc shall touch the centre, and at the termination of each curve angular lines, drawn from end to end, the dotted line is a perfect octagon, as fig. 22. This principle is laid down for perspective.

A rhombus is a parallelogram, whose sides are equal, but not at right angles, as fig. 23.

A rhomboid, whose horizontal lines are equal, and oblique lines unequal, with the horizontal, as fig. 24.

Radius lines. Those lines starting from a centre, and all acute angles, as fig. 25.

Solids and bodies, when either are bounded by surfaces, sides, and ends. A book is solid. Hence a square, with six equal sides, is a solid. or cube; that is to say, in measurement. Twelve inches each way is a foot cube.

When solids or superficies have more sides than one, then they become polygons; if all equal sides, they are regular, if otherwise, irregular, of which they are named up to twelve;

beyond that they are termed polygons of thirteen or fourteen sides, and so on; but I will name the figures, as it is of the greatest utility to know them:—1, a line; 2, a parallelogram; 3, a triangle; 4, a quadrilateral; 5, a pentagon, five sides; 6, a hexagon, six sides; 7, a heptagon, seven sides; 8, an octagon, eight sides; 9, a nonagon, nine sides; 10, a decagon, ten sides; 11, an undecagon, eleven sides; 12, a duodecagon, twelve sides.

Base is the part on which any figure stands. Altitude is the height of any body erect. A circle is a figure bounded by a line, termed the circumference, or periphery, and equi-distant from the centre, or point, from whence it is obtained. The interior of a circle is divided into component parts, each of which has its classification. On reference to the plate, fig. 26, *a b* is the diameter; *c d* is the cord of an arch; and *d b* is the segment of a circle.

Cones may be brought under one head, without entering into the number of terms usually given. Any solid figure rising to an



apex, or point, is called a cone ; if angled, it is called a poly gon-cone, or cone of so many sides ; if the cone be circular, it may be divided into four parts, viz ,—a frustrum of a cone,—that is to say, when it is cut parallel with the base, it is then a circle, as fig. 27 shews. If cut parallel to its axis, it then forms a hyperbolic curve, as *a b c*, fig. 28 ; and if cut parallel to the sides of the cone, it is called a parabolic curve, as *a b c*, fig. 29 ; and if cut through in the angle, it then becomes an ellipsis, as *a*, fig. 30.

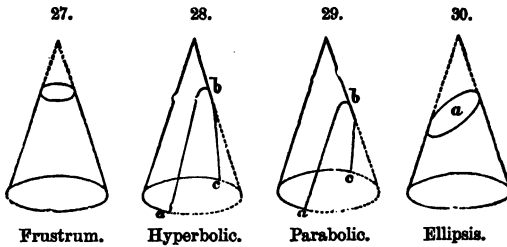

Among the various geometrical figures that become useful to the ornamental draftsman, beside mouldings and archways, are the variety of ovals, ellipses, and foils ; the description of which terminates this volume. There are many who with the compasses can strike an ellipsis,

no doubt, but we will suppose you have no instruments ; it then becomes necessary to be able to do without them, yet work with certainty, and which, with a few useful diagrams, will be found not only essential, but pleasant to study. The first I shall commence with will be the ellipsis, using instruments. Fig. 31 is the elongated ellipsis, and is obtained by two circles, from the centres, $c d$: you gain by the intersecting segments the points, $e f$, from which you pass your diagonal lines, $g h i k$. By placing the compasses on the points $c d$, you strike from h to k , and from g to i ; and from f and e you obtain a curve $g h$ and $i k$, and you have an ellipsis complete ; but let me remind you, in striking any of these geometrical figures, you cannot be too particular as regards your division ; for the least deviation will throw every other portion entirely wrong, and you will have the same work to do over again, for the want of a little care at first ; and where you should have but one point-hole, by carelessness you perforate the paper like

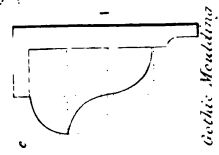
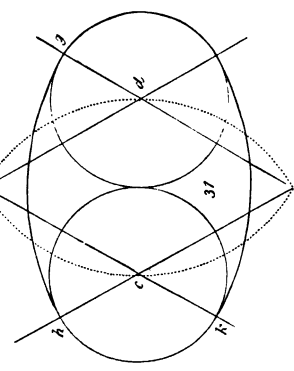
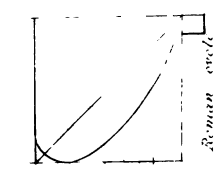
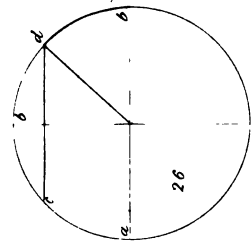
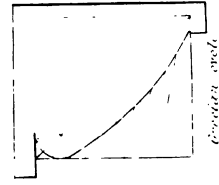
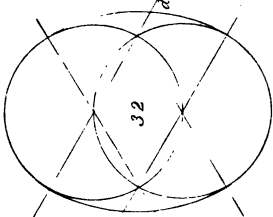
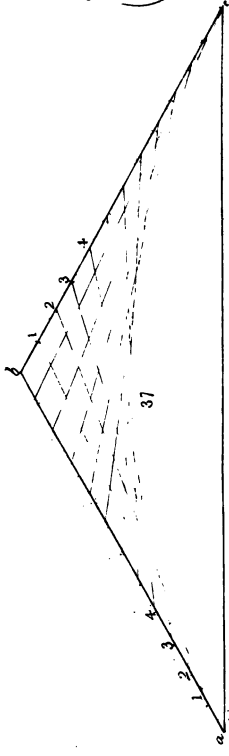
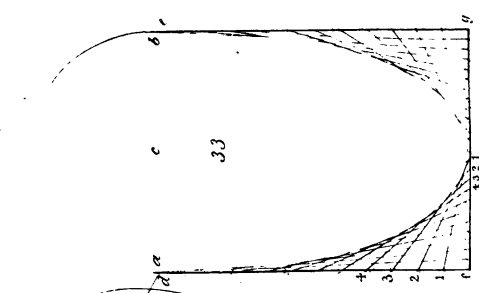
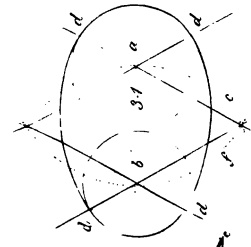

Greater oval

Smaller oval

Circle Moulding

a sieve, which always spoils a drawing; to avoid this, you should get a pair of what are termed spring dividers, to enumerate your divisions, as by that means you can do without pricking the paper so much, by merely laying the points on, and having a screw to work the compasses, you can divide to the greatest nicety, and keep your divisions more true than with the other compasses,—the least pressure of the hand will close them a trifle, which, if imperceptible in one or two divisions, when you come to a hundred, it is then you find it out: this is advice which, perhaps, in the ardour of your studies, you might not think of

Fig. 32 is a short ellipsis, got on the same principle as the first, but instead of forming two tangent circles, you intersect them and work on the former principle.

Fig. 33 is a rule by which the oval is obtained, whatever is to be the width, the length, to be proportionate, must be three times its width, as for instance, the perpendicular line $a b$, is divided from the point c ; strike the

semi-circle, from which you form a parallelogram, *d e f g*, which is to be divided into twelve parts on each side, and the base to be twenty-four parts; by merely intersecting these divisions it will form an oval of itself, viz.—by passing lines from 1 to 1, 2 to 2, 3 to 3, and so on regularly; now, I always found too much trouble in this principle, and could not rest easy until I had found out a much better figure, and on a more simple plan; which, after trying a great many without success, I at last hit upon one, and every person I have shown it to is satisfied of its superiority.

Fig. 34 is an oval, the exterior form of which is gained by two circles, the sizes being governed by the diameter; strike the circle, *a*, then the smaller one, *b*, tangent to it; next strike your intersecting arcs, *c*, which are to be divided into nine equal parts; draw your diagonal lines, *c a b d*, which gives you the stopping points for your segments, *d d d d*, then place the point of the compasses on *f*, and it will give you the segmental curve, *d d d d*;

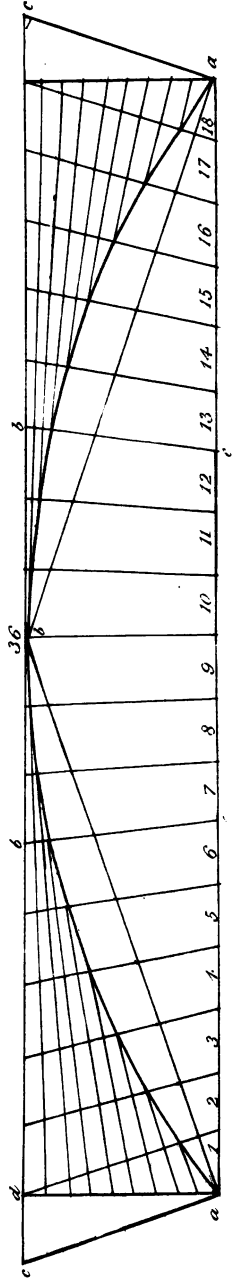
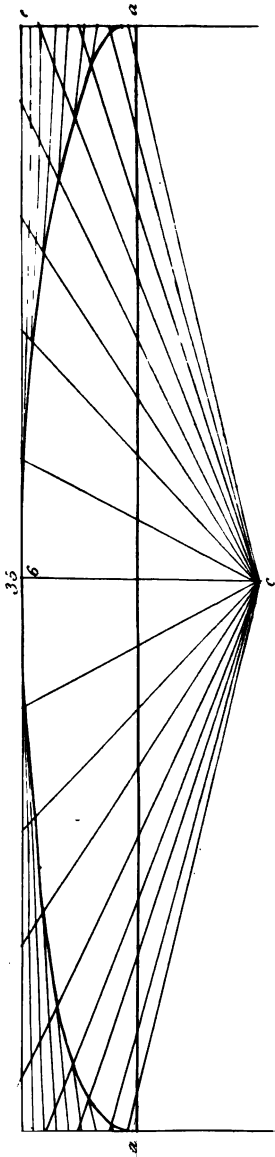

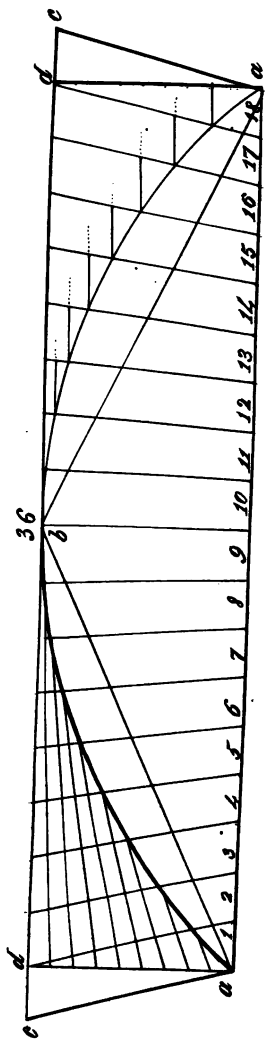
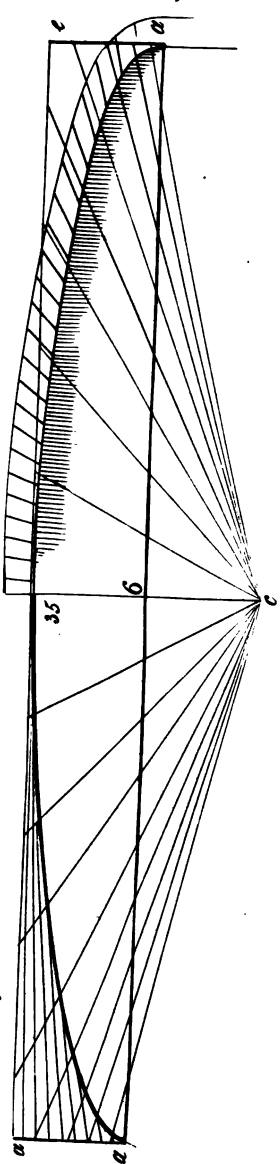

you will find this oval a complete egg shape. Now, we want to obtain a segmental arch and a semi-elliptic, without having sufficient room for striking the same with the compasses; in the connected plate, fig. 35 and 36, I have given two very excellent principles, which I think have not appeared before. The elliptic one is the principle laid down by Rennie, in planning the elliptic arches of New London Bridge. In obtaining or striking this arch, whatever may be the height from your springing line, *a*, the same width you take from that line to carry your radius lines, as at *c*; divide your springing line into eighteen parts, or more, remembering to keep even numbers. The greater the number of divisions, the more certain you are to obtain a segmental line; then carry your radius from the point, *c*, through each of the divisions to the boundary line, *a e*, *a e*; next divide the end, *a e*, in nine equal parts, and from the point, *b*, you carry your lines to the end division, which intersection gives you the arc, *a b c*.

The verse sine arch, fig. 37, is on the same principle, but requires no radius points. Get the height of your arch, and form two acute angles from the base line, $a a$ to b , and on those angles, from the extreme points, a , obtain a right angle, $a c$, $a c$, and another at $a d$, $a d$, which will form one of your divisions of eighteen at the top; and next divide your springing line $a a$, into eighteen equal parts, and your end in nine parts, carry your lines out to $e b$, and your intersecting lines, $b a$, to $b d$, will be the segmental arch.

There is another system by which you may obtain a segment, and which you will find in the plate. The more obtuse the angle, on the sides of which you make a number of divisions, the better the curve appears by the intersection of the numerous divisions; as, from $a b c$ is divided into fourteen parts, cross from 1 to 1, 2 to 2, 3 to 3, 4 to 4, and so on, and the segment is given. This is a very useful diagram, especially when the angle is more acute in its

altitude;—you will find it the only way of describing an hyperbolic curve with facility.

The difficulty of obtaining a quantity of division in a small space, as I before mentioned, with the compasses, I will now draw your attention to. To prevent your perforating the paper like a sieve, divide, for instance, one inch in length into twenty parts; you would, no doubt, go a great many times over that line before you would get the right division, but, on reference to the plate, you will find an unerring principle to work upon. Let $a c$ be the base, at a right angle, with that carry up a perpendicular line, $a b$, of any height, and at random run up your divisions, no matter how many, if you go to work accurately; after this is done, carry a converging line from c to b , and from your base draw parallel lines, touching from side to side, until you have sufficient for your number of divisions, as $d e$; from that, at each intersecting on the angle, carry parallel lines from the perpendicular, e to f ; so, by carrying

these lines to the base, the number of divisions are obtained. This is exceedingly valuable in dividing modules into minutes, in drawing architecture; in fact, in every instance when small divisions are required.

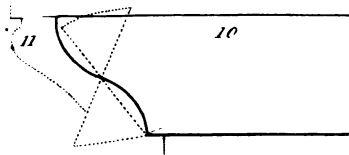
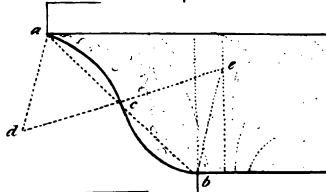
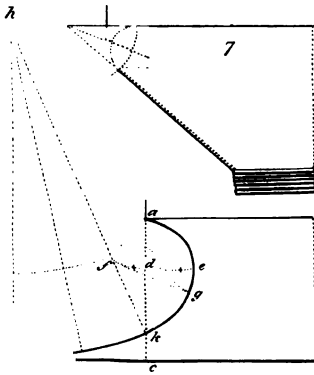
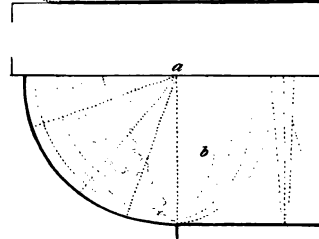
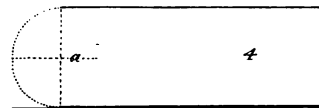
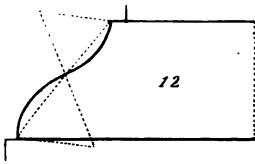
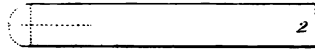
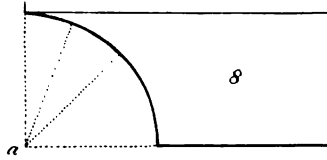
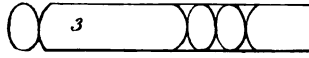
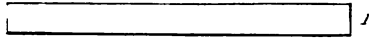

ON MOULDINGS.

MANY of my readers may attribute blame to me for inserting the above-mentioned portions of architecture, and perhaps say, that it has nothing to do with ornament. No: that I will allow. There certainly is no occasion for moulding in a running scroll, but there is in the boundary of it, and that according to the character or style, of course. As a matter of fact, the moulding surrounding it should and ought to be in accordance with it, but it is not always the case; and to prove to you the necessity of such information, is the reason I trespass thus far. This portion of decoration is an indispensable accompaniment to all my former remarks, and co-practice of geometry. As an instance

of the utility of your being acquainted with mouldings, how would an ornamented frieze appear, without the upper mouldings formed a cornice, and protection to all the bas-relief and ornamental risings, and which, in their origin, were of a rude and massive form, brought into a subordinate one by the Greeks, to protect, strengthen, and unite the whole of their buildings?

The number of mouldings generally used are eight, and each and every one of utility. The first and most simple form is the fillet, fig. 1, which is the smallest in proportion to the whole of the others, and its chief use is to divide the superior mouldings, and prevent the heavy inharmonious effect that would be produced by two or more geometrical mouldings being placed together.

Fig. 2 is the astragal, or round fillet, which may be, if required, ornamented as fig. 3. Its chief use is to divide the capital from the shaft of any column or pilaster, and may be either entirely round, or semi-circular.



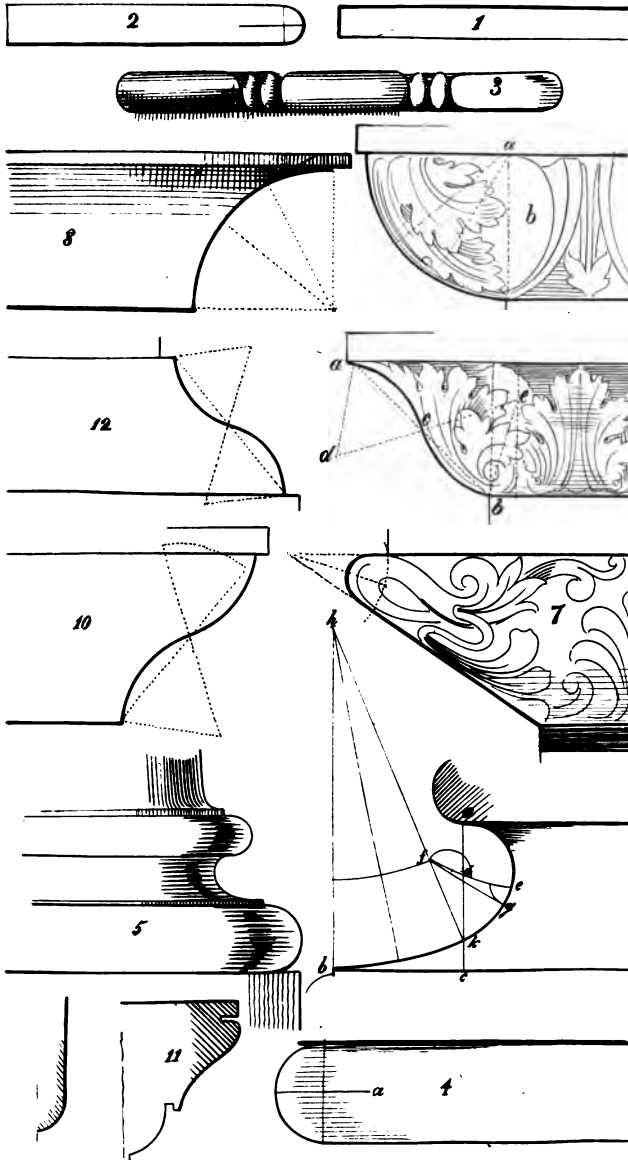

Fig. 4 is of the same character, but of a much bolder form, and chiefly used in the base moulding of a column, and termed alorus. The exterior end is got from the point *a*, and projects no further than the vertical line in face of the plinth, as fig. 5.

Fig. 6 is the ovolo, or quarter round, and is now chiefly used in an admixture of Roman mouldings; but there is so massive an appearance with it, that, at the present day, the inventive genius of architects has greatly improved upon it and adhered more strictly to what is termed the Grecian ovolo, as fig. 7, which is much lighter and more graceful in appearance. Fig. 6 is the quarter of a circle, and gained from the point, *a*; but the Grecian is got from any acute angle. You may allow for the projection and depth of your moulding, from any angle you please, keeping the circular end in proportion, as fig. 7.

Fig. 8 is termed the cavetto, or hollow. This moulding was chiefly used by the Egyptians, surrounding their temples, as I have

before described; it is chiefly employed in covering the other members; and, being strong at the extreme points, supports others. This is obtained from the point, *a*.

Fig. 9 is the *cyma-recta*, or *cymatium*. When you have ascertained the projection of your moulding, draw the angular line, *a b*, which you will divide into two equal parts, as at *c*; which divisions will form the bases for two equilateral triangles, as *a e d*, and *c b e*. From the point *e*, you strike *c b*, and from *d*, *a c*; which when joined, is the *cymatreum* of the moulding.

Fig. 10 is the *ogee*, and drawn in the same manner as fig. 9, but reversed. It is a moulding well adapted to support other members, from the strength of its extreme points. A very rich effect is produced in this moulding by turning the top end, and leaving a small opening, as fig. 11 shews, and is termed a *quirked* moulding, by having the appearance of a black line, by the indentation of the hollow under the fillet.

Fig. 12 is the *cyma-reversa*, and the same

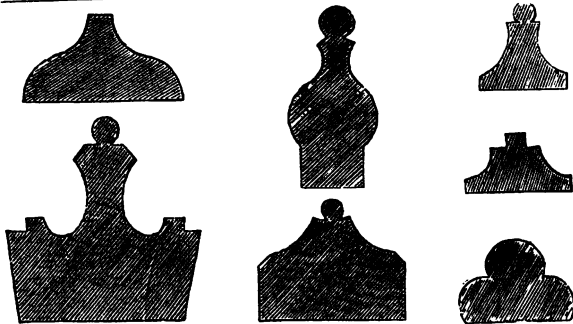
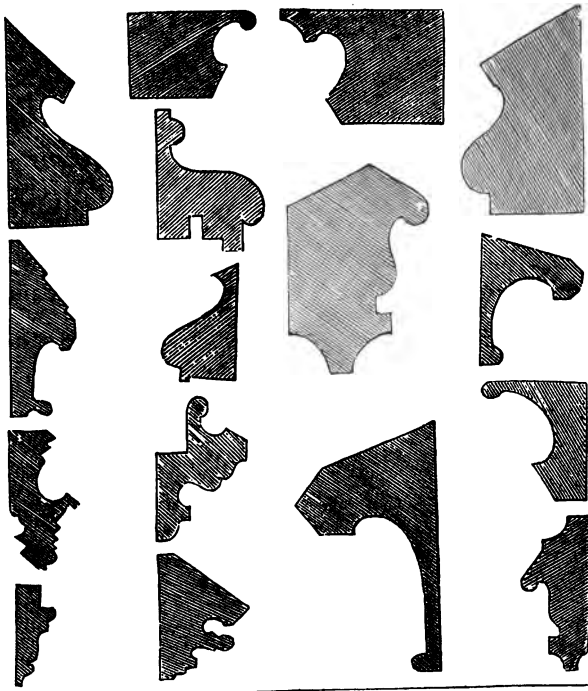

Those above the line are sections of Gothic mouldings;—those below, are termed mullions, or sections of the upright bars and tracery in various Gothic windows.

as the above, in an inverted position and used for base mouldings only.

Fig. 13 is a very peculiar moulding, and used to give power to the surrounding members, and to effect a good profile:—it is termed a scotia mouth. After you have determined the projection of your top and bottom extremity, as *a b*, the perpendicular line, *a c*, is divided into three equal parts, and from the point, *d*, describe the quarter circle, *a e*; then divide the horizontal line, *e f*, into five equal parts. From the point, *f*, draw *e g*, and by striking an arc from the point, *f*, from the two inner divisions, will give you the point to intersect your angle, *c h*, and from that angle you raise your perpendicular, *b h*, the extremity of which you divide into three equal parts; then strike the arc, *g k*; from that you strike the remainder of the arc, to complete the mouldings, from *h*, which is from *k* to *b*. This moulding is an excellent study, and I would advise you not to be conquered by the seeming difficulty of its appearance.

There is another more simple way of obtaining this moulding, by merely dividing the height into three parts, two for which will form the width, by intersecting six parts, as diagram. The point, *a*, will give you the arc from *b c*, and from the point, *d*, will form the other arc, *c e*.

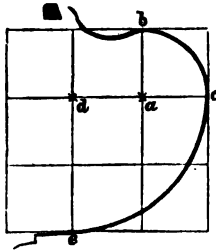

I think I have treated on every thing necessary for your instruction, according to my promise; and as my last advice (although it has been repeated before) is, study well and assiduously that which is good, and feel not daunted at trifling obstacles that may occur; for, rest assured, after surmounting one, you will not rest, until you have surmounted others, and overtopped the apex of difficulties;—then all must run smooth, and your labours be repaid: and whilst you are performing these energetic feats of perseverance to reach perfection in the arts, you will be viewed with a jealous eye by your fellow-students, until they exert them-

selves in the same manner. Then, by those means, the art of design ere long must become . extended, and hold the crayon of superiority over all other countries.



FINIS.